



A^{RF18} 4 relays receiver



User Guide

No part of this document may be reproduced or transmitted (in electronic or paper version, photocopy) without Adeunis RF consent.

This document is subject to change without notice.

All trademarks mentioned in this guide are the property of their respective owner.

ADEUNIS RF

283, rue Louis Néel

38920 Crolles

France

Phone +33 (0)4 76 92 07 77

Fax +33 (0)4 76 08 97 46

Ref. 07-06-V4-ptr

Table of contents

Declaration of conformity	3
Presentation.....	4
Product installation.....	4
Supply voltage.....	5
Dry contact connection.....	6
Learning process procedure.....	7
Standard learning description	7
Standard use cases	9
Standard learning PROCEDURE.....	11
Advanced learning description	11
Advanced use cases	11
Advanced learning procedure	13
Global erase procedure (remove all remotes control)	14
Bistable / monostable operation.....	14
Switches usage summary	15
Antenna wiring.....	17
Specifications	18

About this document

This guide describes the A^{RF18} devices, their options and accessories.

Declaration of conformity



Manufacturer's name:
Manufacturer's address

ADEUNIS R.F.
Parc Technologique PRE ROUX IV
283 rue Louis NEEL
38920 CROLLES - FRANCE

declares that the product if used and installed according to the user guide available on our web site www.adeunis-rf.com

Product Name: **ARF18**
Product Number(s): **ARF7341B**

Product options:

Complies with the RTTE Directive 99/5/EC:

EMC: conformity is proven by compliance to the harmonized standard EN 301-489
Safety: conformity to the standard EN 60950-1/2001
Radio: conformity is proven by compliance to harmonized standard EN 300-220 covering essential radio requirements of the RTTE directive.

Exposure to radio frequency signals according to the council recommendation 1999/519/EC on the limitation of exposure of general public to electromagnetic field.

Notes: - Conformity has been evaluated according to the procedure described in Annex III of the RTTE directive.

- Receiver class (if applicable): 3.
Crolles, November 6th, 2007
VINCENT Hervé / Quality manager

A handwritten signature in black ink, appearing to read 'VINCENT', is written over the printed name 'VINCENT Hervé / Quality manager'.

Download of the user guide

Thank you for having chosen the ADEUNIS RF products.

User guides can be uploaded directly on our web site www.adeunis-rf.com

Index **Products**

Paragraph **Remote control > Remote control & receivers**

Print version available upon request

- ✓ Tel : +33 4 76 92 07 77
- ✓ Email : arf@adeunis-rf.com

Presentation

The ARF7341 receiver controls 4 relays according to orders sent by ARF7291 remote controls.

It is a one-way system, the system behaves as 4 links.

The link between remote control and receiver is only effective after a learning phase.

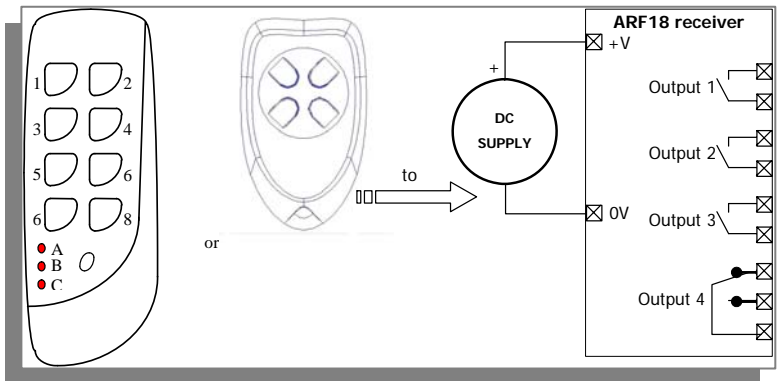

Product installation

The ARF7341 receivers are fixed by the fixing lugs onto the top (antenna) and bottom (stuffing box) parts of the housing. Any operation (drilling...) performed on the housing makes it lose its IP65 tightness rating.

Remove the two stainless steel screws (A and B) and take the bottom part off to access the power supply terminal blocks and contacts.

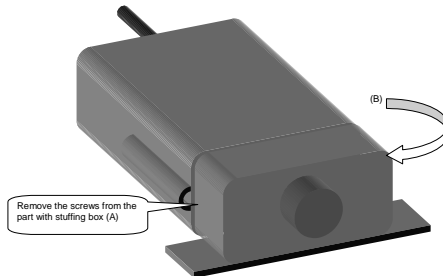

Supply voltage

Turn off the voltage supply, then wire the power supply up to the screw terminals marked + and -.

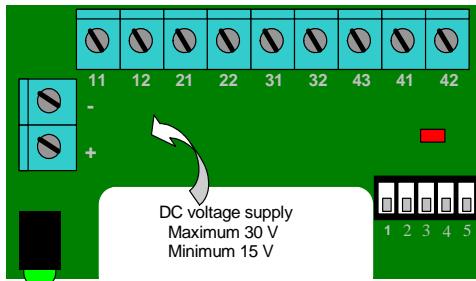

Dry contact connection

The ARF7341 receiver has 3 relays with a single Normally Opened (NO) contact and one relay with NO and Normally Closed (NC) contacts. The switching capacity of the contact is 10A / 230V. They can be used in monostable or bistable mode (by group of 2 relays: relays 1-2 and relays 3-4).

In bistable mode, the output toggles at each reception (the state of the contact is toggled each time a remote control key is pressed),

In monostable mode the relay is closed during reception (while the remote control key is pressed)

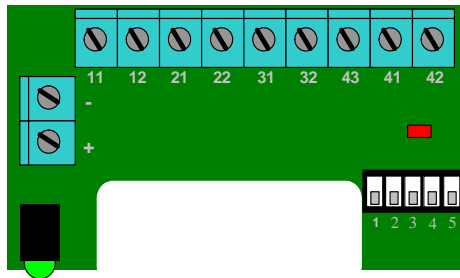

Wiring example :

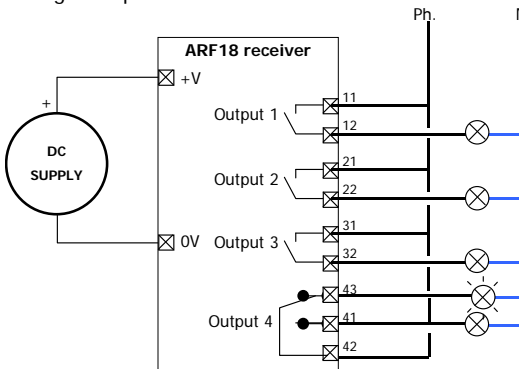

Learning process procedure

Up to 83 remote controls can be stored for a receiver.

It is recommended for this operation not to supply power to the contacts from the mains.

This chapter describes the procedure to associate a remote control with ARF7341's outputs; this association is also known as learning procedure. This procedure is mandatory.

This chapter also describes how to remove all remotes control associated to the receiver.

The learning process is initiated by the 5 switches SW1 to SW5; Two kinds of configuration can be done:

1. standard learning procedure, covering 99% of industrial applications
2. Advanced learning procedure, for very few specific applications

Standard learning description

The standard learning allows associating in an ordered way the 4 outputs to 4 remote control keys :

For remote control with 4 keys or less the association will be :

- key 1 → relay1
- key 2 → relay2
- key 3 → relay3
- key 4 → relay4

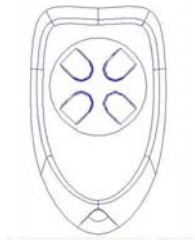

For remote control with 24 keys the association will be :

key 1 → relay1
 key 2 → relay2
 key 3 → relay3
 key 4 → relay4.

or

key 5 → relay1
 key 6 → relay2
 key 7 → relay3
 key 8 → relay4.

or

...

or

key 21 → relay1
 key 22 → relay2
 key 23 → relay3
 key 24 → relay4.

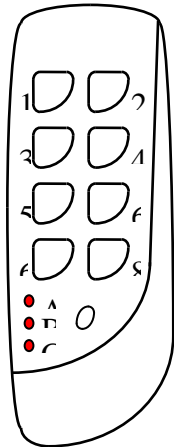

For a 24 remote control, the keys are accessible through 3 different banks (A, B, C). The small key allows bank change.

When led A lit,
 Key 1 to 8

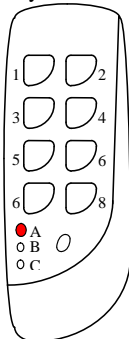

When led B lit,
 Key 9 to 16

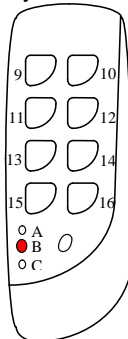

When led C lit,
 Key 17 to 24

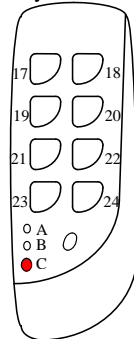

Standard use cases

This paragraph presents a subset of standard usage.

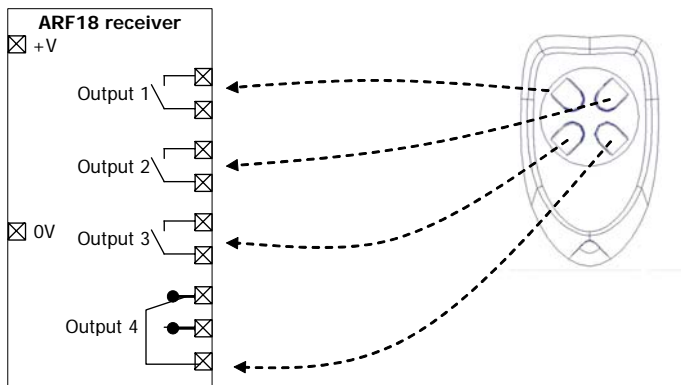

Figure 1: output 1 to 4 driven by key 1 to key 4

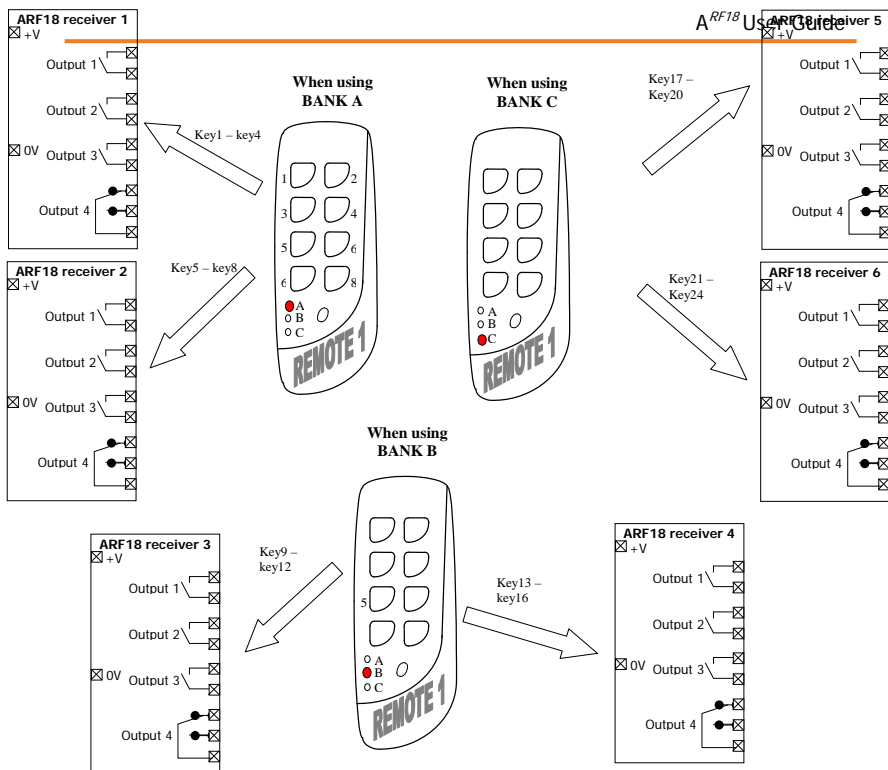

Figure 2: 6 receivers driven only by 1 remote control with 24 keys

Standard learning PROCEDURE

<p>Global ADD / REMOVE OPERATION</p> <p>1/ Select the "Add/Remove" mode by SW5 ON. 2/ Select SW3 ON and SW4 OFF. 3/ Press any key of the remote control. 4/ Exit the "Add/Remove" mode by SW5 OFF.</p>
<p>Two possible results of operation:</p> <p>Previously, this remote control wasn't driving any of the relays of the receiver: the following links are created in the receiver's database for this remote control: key 1 drives relay 1, key 2 drives relay 2, key 3 drives relay 3, key 4 drives relay 4. The led blinks once.</p> <p>Previously, this remote control was driving at least one of the relays of the receiver: all the links between this remote control and the relays will be removed. The LED blinks twice.</p>

Advanced learning description

The Advanced learning is restricted to key 1 up to key 4 (only available for key 1 to key 4 of a 24 keys remote control).

The following associations could be done:

Any remote control key can drive any of the output of the receiver.

One or more remote control can drive the same outputs.

Any remote control key is able to drive from 1 to 4 outputs of the receiver.

Advanced use cases

This paragraph illustrates some advance usages.

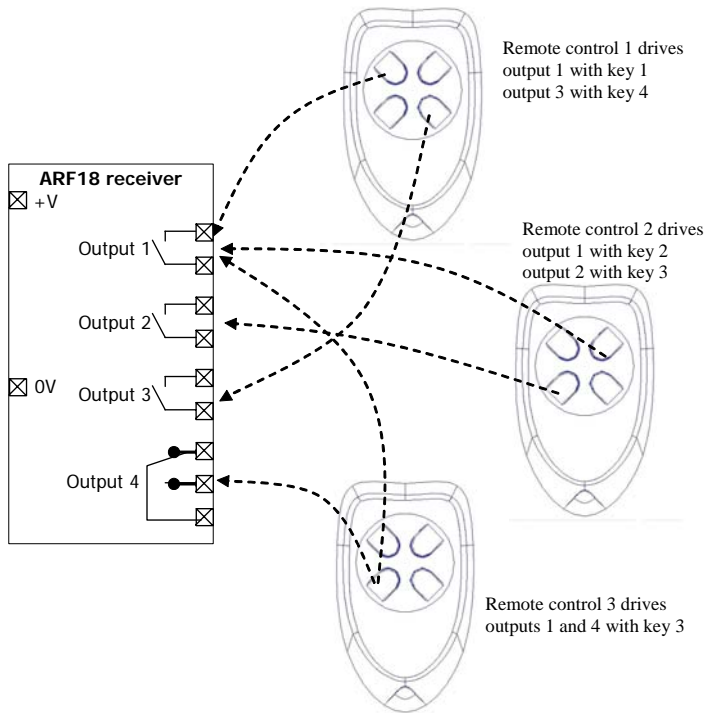

Figure 3: Any remote control key can drive any of the output of the receiver

Advanced learning procedure

ADD / REMOVE OPERATION for a selected relay

- 1/ Select the "Add/Remove" mode by SW5 ON.
- 2/ Select SW3 OFF and SW4 OFF.
- 3/ Select the relay that the remote control will drive by setting SW1 and SW2 (see Table 1).
- 4/ Press the key of the remote control which will drive the relay selected.
- 5/ Exit the "Add/Remove" mode by SW5 OFF.

Two possible results of operation:

- **This association was not set previously. The association is set. The LED blinks once.**
- **This association was set previously. The association is removed. The LED blinks twice.**

ERASE OPERATION for a selected relay

- 1/ Select the "Erase" mode by SW4 ON.
- 2/ Select SW3 OFF and SW5 OFF.
- 3/ Select the relay for which the associations have to be removed by setting SW1 and SW2 (see Table 1).
- 4/ Press the key of any remote control to perform operation.
- 5/ Exit the "Erase" mode by SW4 OFF.

Result of operation:

The selected output can no more be activated by any remote control. The LED blinks twice.

SW1	SW2	Relay1	Relay2	Relay3	Relay4
OFF	OFF	Selected			
ON	OFF		Selected		
OFF	ON			selected	
ON	ON				selected

Table 1: relay selection in advanced learning mode

CAUTION

In advanced learning mode, mixing remotes control with 4 keys (key 1 up to key 4) and “key number higher than 4” (key 5 up to 24) must be done carefully:

An ADD operation for a selected relay with a key ≥ 5 will be seen as a global add (for example key 5 will be associated to relay1, key 6 will be associated to relay2, key 7 will be associated to relay3, key 8 will be associated to relay4)

A REMOVE operation for a selected relay will perform a global remove if the record has been performed for a key ≥ 5 (for example if key 5 is associated to relay1, key 6 to relay2, key 7 to relay3, key 8 to relay4, ALL the associations will be removed)

An ERASE operation for a selected relay will perform a global erase if the record has been performed for a key ≥ 5 (for example if key 5 is associated to relay1, key 6 to relay2, key 7 to relay3, key 8 to relay4, ALL the associations will be erased).

Global erase procedure (remove all remotes control)

Global ERASE OPERATION
1/ Select the “Erase” mode by SW4 ON. 2/ Select SW3 ON and SW5 OFF. 3/ Press any key of any valid remote control. 4/ Exit the “Erase” mode by SW4 OFF.
Result of operation: All the relays can no more be activated by any remote control. The LED blinks twice.

Bistable / monostable operation

In operating mode (when the learning has been done), the user can choose if the relays operate either in monostable or bistable. As depicted hereafter SW3-SW4-SW5 must be set to OFF.

SW1	Relays 1 and 2	SW3-SW4-SW5
OFF	Monostable	OFF-OFF-OFF
ON	Bistable	OFF-OFF-OFF

SW2	Relays 3 and 4	SW3-SW4-SW5
OFF	Monostable	OFF-OFF-OFF
ON	Bistable	OFF-OFF-OFF

Switches usage summary

This paragraph summarizes the switches functionality. For a standard usage (learning) this paragraph has no added value and can be ignored. The knowledge of the switch usage is only required for advanced usage.

In particular this paragraph highlights how to choose a specific relay for advanced learning procedure.

Switch number	Function	Description
SW5	Add/Remove	SW5 OFF : "Add/Remove" function is not activated. SW5 ON : "Add/Remove" function is activated
SW4	Erase	SW4 OFF : "Erase" function is not activated. SW4 ON : "Erase" function is activated.

SW1 and SW2	Relays selection or operating mode selection (monostable or bistable)	<p>→When module is set in learning mode, (“Add/Remove” or “Erase” activated), “SW1” and “SW2” selects the relay to configure:</p> <table style="margin-left: auto; margin-right: auto;"> <thead> <tr> <th style="text-align: center;">SW2</th> <th style="text-align: center;">SW1</th> <th style="text-align: center;">Relay selected</th> </tr> </thead> <tbody> <tr> <td></td> <td>ON</td> <td>ON</td> </tr> <tr> <td></td> <td>ON</td> <td>4</td> </tr> <tr> <td></td> <td>OFF</td> <td>ON</td> </tr> <tr> <td></td> <td>OFF</td> <td>3</td> </tr> <tr> <td></td> <td>OFF</td> <td>OFF</td> </tr> <tr> <td></td> <td>ON</td> <td>2</td> </tr> <tr> <td></td> <td>OFF</td> <td>OFF</td> </tr> <tr> <td></td> <td>OFF</td> <td>1</td> </tr> </tbody> </table> <p>→When module is not in learning mode, the “SW1” input selects the operating mode of relays 1 and 2 and “SW2” selects the operating mode of relays 3 and 4.</p> <ul style="list-style-type: none"> • SW1 ON : relays 1 and 2 in bistable mode. • SW1 OFF : relays 1 and 2 in monostable mode. • SW2 ON: relays 3 and 4 in bistable mode. • SW2 OFF : relays 3 and 4 in monostable mode. 	SW2	SW1	Relay selected		ON	ON		ON	4		OFF	ON		OFF	3		OFF	OFF		ON	2		OFF	OFF		OFF	1
SW2	SW1	Relay selected																											
	ON	ON																											
	ON	4																											
	OFF	ON																											
	OFF	3																											
	OFF	OFF																											
	ON	2																											
	OFF	OFF																											
	OFF	1																											

SW3	Global	<p>SW3 is used to determine if learning operation is performed for all relays or not.</p> <p>➔ SW3 ON : the learning operation is performed for all relays (SW1 and SW2 are ignored). The functionality depends on the function selected ("Erase" SW4 or "Add/Remove" SW5). Further details for the Global add/remove and Global erase operations are described in the following tables.</p> <p>➔ SW3 OFF : the learning operation only applies to the relays selected with SW1 and SW2.</p>
-----	--------	--

Antenna wiring

In daughter-board version, an antenna has to be added to achieve correct communication between the products. This antenna should be a wire with a length of $\frac{1}{4}$ wave, i.e. about 17 cm. This length is that which has to extend outside the housing if the latter is metallic.

This antenna can be located remotely using a coaxial cable with its braid stripped over the last 17 centimeters.

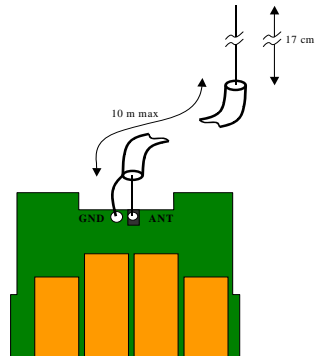

Specifications

Radio characteristics

Frequency :	433.92 MHz
Modulation :	ASK
Sensitivity :	-104 dBm

Electrical characteristics

Power supply (VCC) :	15 to 30 V _{DC}
Consumption (all relays opened) :	30mA
Consumption (all relays closed) :	85mA
Switching capacity :	230V I _{max} 10 A

Relay characteristics

Contacts
 3 relays with 1 NO
 1 relay with 1 NO / NC

Mechanical characteristics

Size (mm) :	Board: 65 x 90 x 25mm
Ip65 box :	104 x 300 x 35mm
Connector block	
Connection by M3 screw	
1.5/2.5mm ²	
Operating temperature :	-20 to +70 °C

References

- ARF7341A: 4-relays receiver board**
- ARF7341B: 4-relays receiver in IP65 housing**
- ARF7291A: 1-key remote control**
- ARF7291B: 2-key remote control**
- ARF7291C: 3-key remote control**
- ARF7291D: 4-key remote control**
- ARF7291R : 8/24-key remote control**