

# ARF20 Digital User Guide



<b>PRESENTATION</b>	<b>3</b>
<b>PRODUCT POWER SUPPLY</b>	<b>4</b>
<b>ASSOCIATING A TRANSMITTER TO A RECEIVER</b>	<b>5</b>
<i>Open collector receiver</i>	<b>5</b>
<i>Relay receiver</i>	<b>6</b>
<i>Memory clear on ARF6189 receiver</i>	<b>7</b>
<i>Memory clear on ARF6678 receiver</i>	<b>7</b>
<b>INPUT WIRING</b>	<b>8</b>
<i>3-wire sensor connection</i>	<b>10</b>
<i>Dry contact connection.</i>	<b>10</b>
<b>ANTENNA WIRING</b>	<b>11</b>
<b>OUTPUT WIRING</b>	<b>11</b>
<i>Binary outputs</i>	<b>12</b>
<i>Validity output on ARF6189</i>	<b>13</b>
<i>Relay output connection.</i>	<b>13</b>
<i>Validity output on ARF6678</i>	<b>15</b>
<b>SYNCHRO MODE</b>	<b>16</b>
<b>SERIAL OUTPUT</b>	<b>17</b>
<b>BOARD DIMENSIONS</b>	<b>17</b>
<b>TECHNICAL DATA</b>	<b>18</b>
<i>Transmitter</i>	<b>19</b>
<i>Receivers</i>	<b>19</b>
<i>Conversion</i>	<b>19</b>
<i>Dimensions</i>	<b>19</b>
<i>References</i>	<b>19</b>

## DECLARATION OF CONFORMITY

according to ISO/IEC Guide 22 and EN45014



Manufacturer's name: **ADEUNIS R.F.**

Manufacturer's address: Parc technologique PRE ROUX IV  
283 rue Paul Louis NEEL  
38920 CROLLES - FRANCE

declares that the product

Product Name: ARF20  
Product Number(s): ARF6188B / ARF6189B / ARF6678B  
Product options:

conforms to the RTTE Directive 99/5/EC :

EMC: conformity is proven by compliance to the standard EN 301489 according to the requirements of EMC Directive 89/336/EEC.

Safety: conformity to the standard EN 60950 according to the requirements of Low Voltage Directive 73/23/EEC.

Radio: conformity is proven by compliance to harmonised standard EN 300220 covering essential radio requirements of the RTTE directive.

Notes: 

- Conformity has been evaluated according to the procedure described in Annex III of the RTTE directive.
- The use of the spectrum is harmonised by the fact that the product never falls in one of the restrictions listed in appendix 3 (Annex 1, band E) of the CEPT recommendation 70-03.
- Receiver class (if applicable): 2.

Crolles, April 4<sup>th</sup>, 2001

VINCENT Hervé / Quality manager

## PRESENTATION

The ARF20 system enables logic states to be transmitted from one point to another. It is a one-way system: the transmitter transmits these states by radio channel and the receiver decodes the messages received and restores them on binary outputs. There are 3 product references in the range, the ARF6188 transmitter and 2 receivers - ARF6189 (open collector output) and ARF6678 (relay output).

The product behaves like 8 parallel links: output 1 corresponds to input 1, output 2 to input 2 etc.

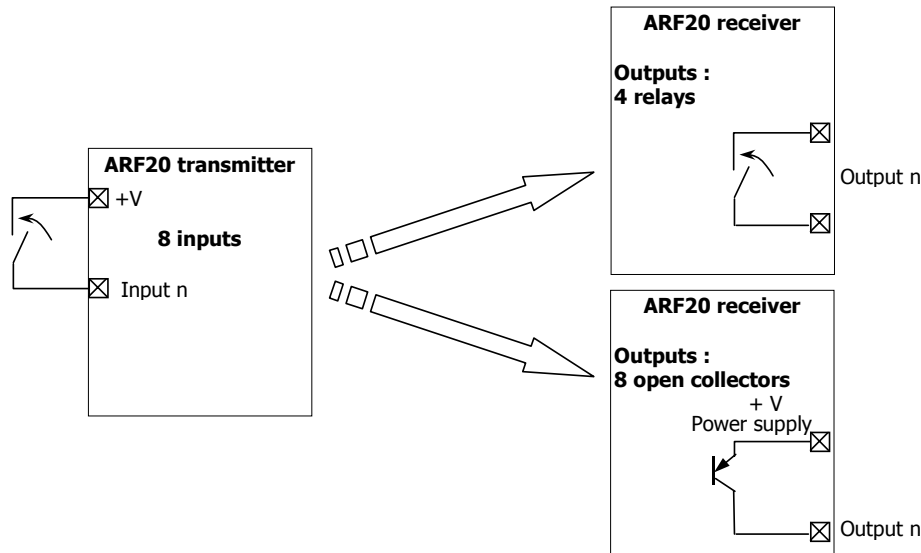

The radio link is established successively on 3 frequencies. Only one of these 3 frequencies is necessary to establish the outputs.

The transmitter scans its inputs continuously and triggers a radio transmission every 100 ms.

The link between transmitters and receivers is only effective after a learning phase.

The products are available either in board version to be integrated in an assembly or as an IP65 enclosure. In the latter case the products are fixed by the fixing lugs onto the top (antenna) and bottom (stuffing box) parts of the enclosure housing (4 screws not supplied).

## PRODUCT POWER SUPPLY

To perform wiring of these products, the bottom part of the housing (part with stuffing box) has to be opened by unscrewing the two stainless steel screws on each side.

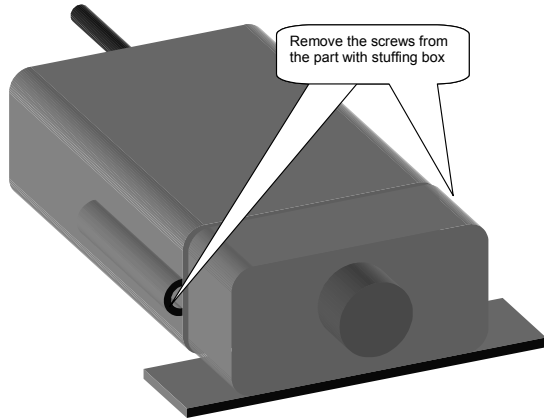

**On the 4-relay receiver, turn off any mains power that may be present on the relays before opening the housing.**

The ARF20 range products are supplied with a **DC voltage** source. This voltage supply must not exceed 30 V<sub>DC</sub>.

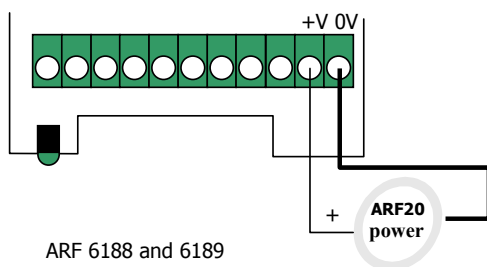

OR

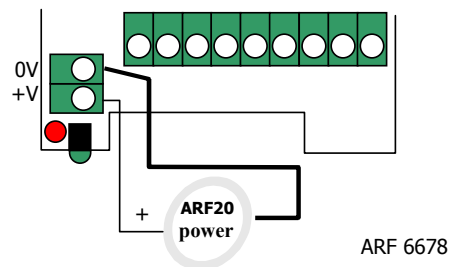

## ASSOCIATING A TRANSMITTER TO A RECEIVER

- Open collector receiver

The red ON led flashes twice and the green RX led is not lit, the product is correctly supplied but there is no transmitter associated to the receiver and the product cannot operate.

On the receiver, set the switch marked AP to ON to switch to learning mode. The red led flashes.

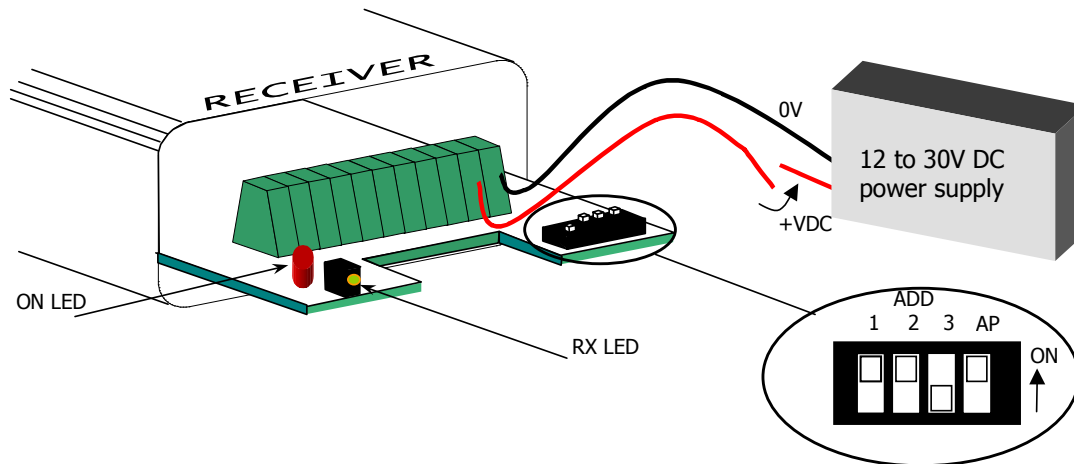

- Set the switches ADD 1, 2 and 3 to the same positions on the transmitter and receiver.
- On the transmitter to be associated to the receiver, set the TR00 switch to OFF and the SYNC switch to ON, then set the power on. In this configuration the transmitter sends radio frames, whatever the state of its inputs is.

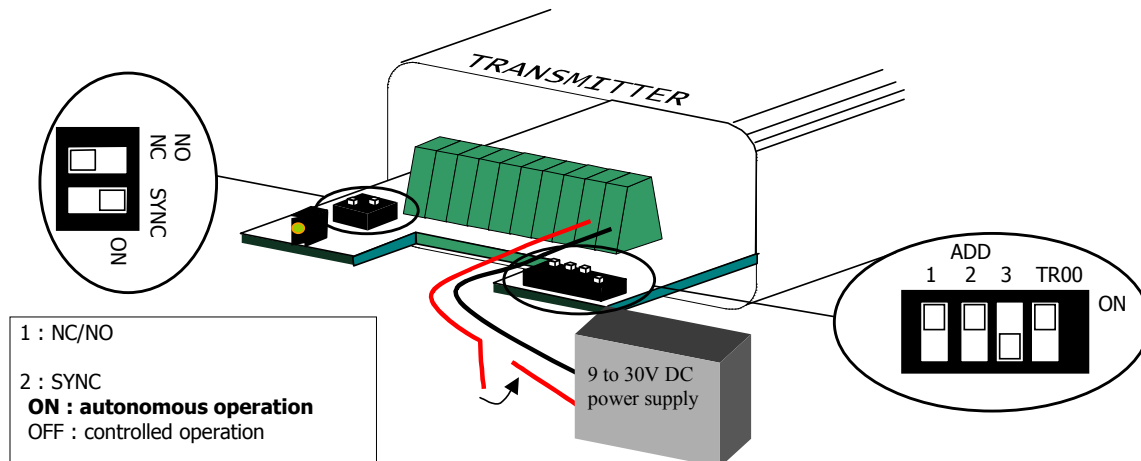

After a few seconds, the green led on the receiver lights up continuously and the transmitter has been memorised. Stop transmission and, on the receiver, switch the learning switch AP to OFF. The red ON led should be lit continuously and the product is ready to operate. The green RX led then lights up at each receipt.

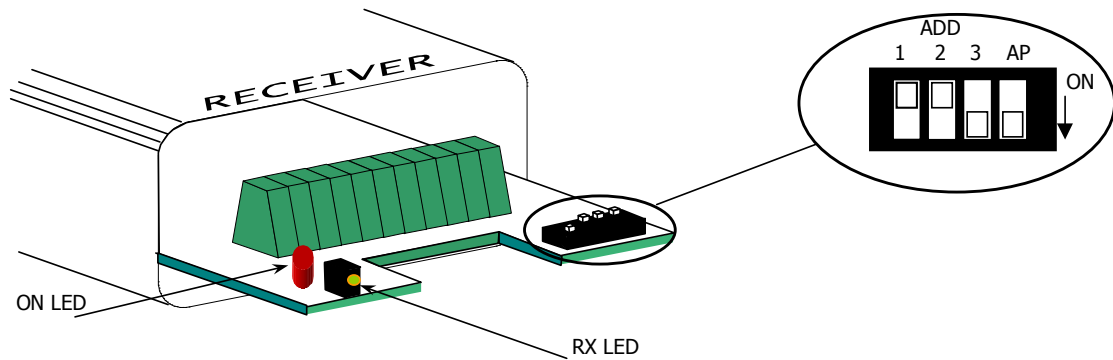

- Relay receiver

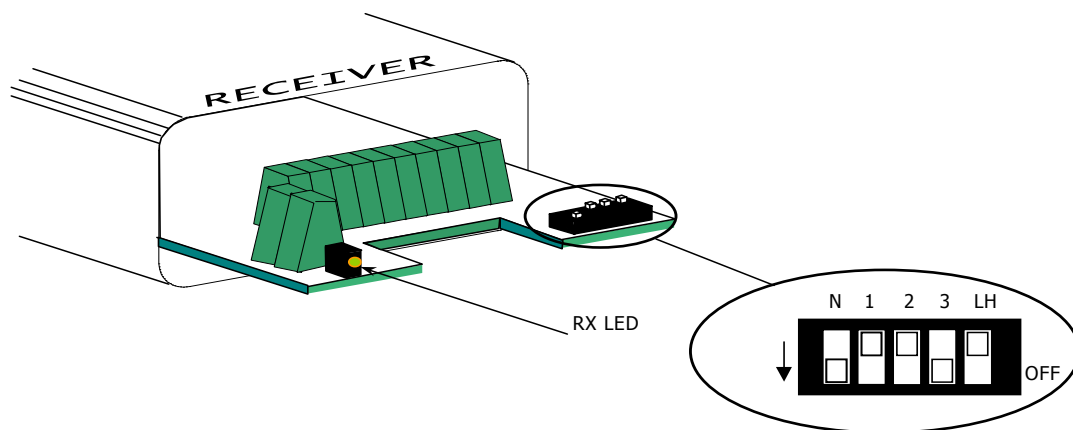

The learning procedure is identical, but the switch settings differ slightly (perform the operations in the order set out below):

- Set switch #1 (N/P) to ON (normal mode) and set the next 3 switches (C1, C2, C3) to the same positions as on the transmitter.
- Move switch #1 to OFF (programming mode), then set switches #2 to 5 to OFF. Then move switch 2 (AP) to ON to set the product to learning mode.
- On the transmitter to be associated to the receiver, set the TR00 and SYNC switches to ON then power it on. In this configuration the transmitter sends radio frames whatever the state of its inputs.
- When learning has been completed (green led continuously lit), move switch #2 to OFF.
- Reset switch #1 (N/P) to ON (normal mode) and set the next 3 switches (C1, C2, C3) to the same positions as on the transmitter.

Notes:

1. An infinite number of receivers can be associated to a transmitter. Inversely several transmitters can be associated to a receiver provided that transmissions are **extremely rare** (TR00 must be set to ON).
2. There can be several pairs of ARF20's in parallel on the same site. For this, they must not operate on the same channel. In this case choose addresses separated by 3, e.g. 1 (OFF, ON, ON) and 4 (ON, ON, OFF).

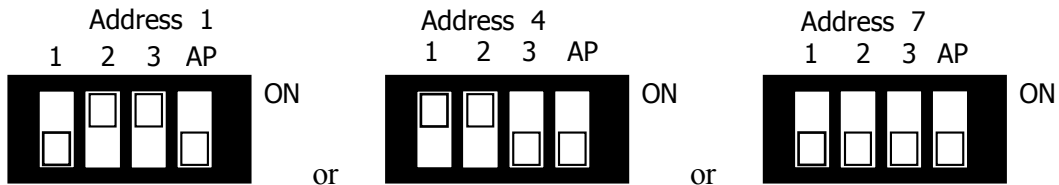

- **Memory clear on ARF6189 receiver**

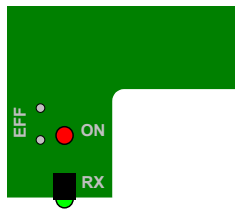

To clear all the recorded serial numbers from the receiver memory, the two pads to the left of the red led have to be short-circuited. The red led then flashes. Maintain the short-circuit until the green led lights up: the memory has then been cleared.

- **Memory clear on ARF6678 receiver**

- Set switch #1 to OFF (programming mode), then set switches #2 to 5 to OFF. Then move switch #3 to ON (EF) to run the clear procedure.
- After 6 seconds, the memory clear has been completed, the green led is lit continuously. Move switch #3 to the OFF position.
- Reset switch #1 (N/P) to ON (normal mode) – the red led flashes indicating that the product can no longer operate.

## INPUT WIRING

The inputs are wired on the transmitter. All the inputs are defined either normally open (NO) or normally closed (NC).

- In NO mode (NO/NC on ON), an input is active if the voltage present on the terminal block is greater than  $+V_{\text{supply}}/2$ . If the input is not connected or is at a voltage lower than  $V_{\text{supply}}/2$  the input is inactive. In this case, closing of a contact between the power supply and an input will make the associated relay on the receiver close.
- In NC mode (NO/NC on OFF), an input is active if the voltage present on the terminal block is lower than  $+V_{\text{supply}}/2$  or not connected. If the input is at a voltage greater than  $V_{\text{supply}}/2$  the input is inactive. In this case, closing of a contact between the power supply and an input will make the associated relay on the receiver open.

**⚠** The  $V_{\text{supply}}/2$  threshold is not precise. For greater safety a low level should be considered if the voltage is less than  $V_{\text{supply}}/3$  and a high level if the voltage is more than  $2 V_{\text{supply}}/3$ .

The presence of at least one active input triggers transmission.

When all the inputs are inactive, radio transmission can be interrupted or maintained:

- When TR00 is on ON, there is no transmission when all the inputs are inactive.
- When TR00 is on OFF, transmission is continuous whatever the state of the inputs.

These two operating options are to be chosen with the product powered off: they will be taken into account at the next power-up.

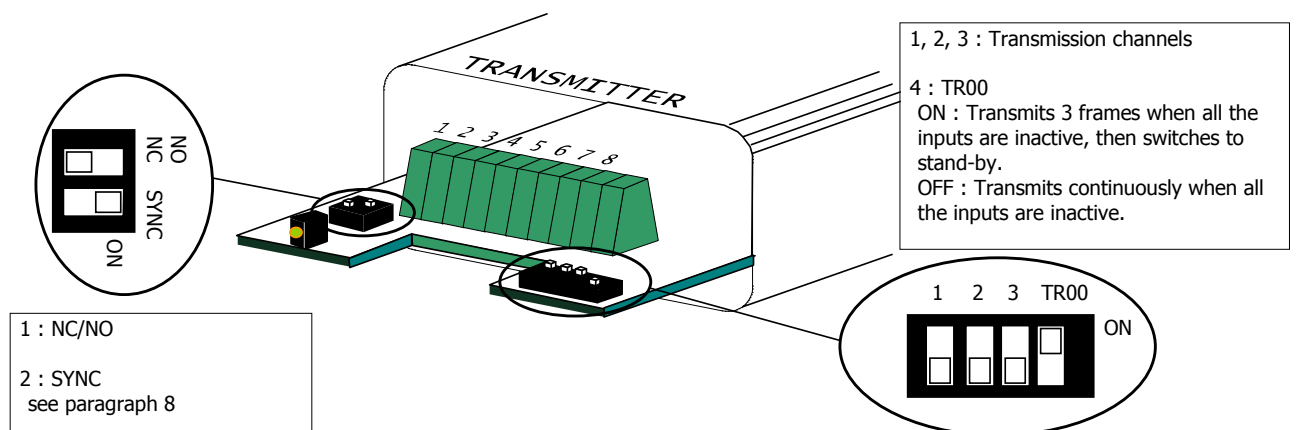

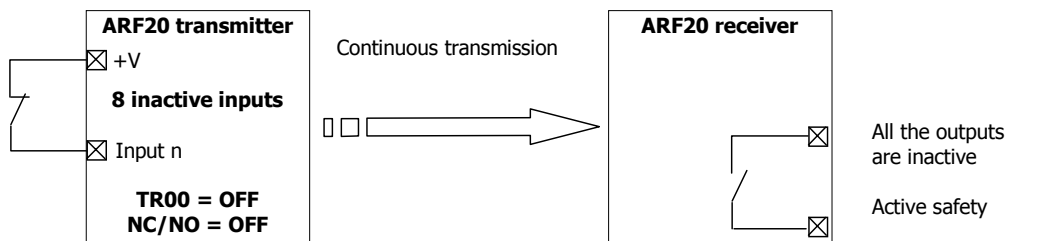
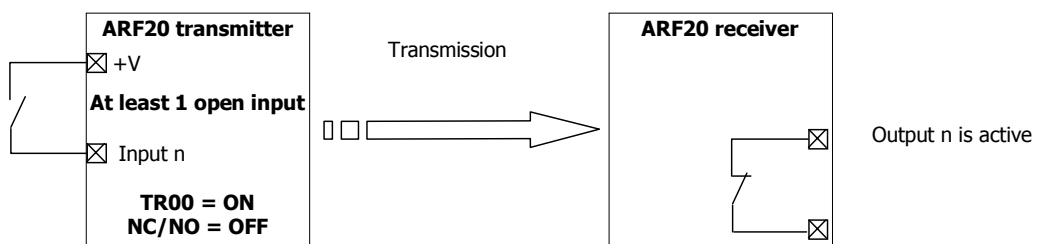
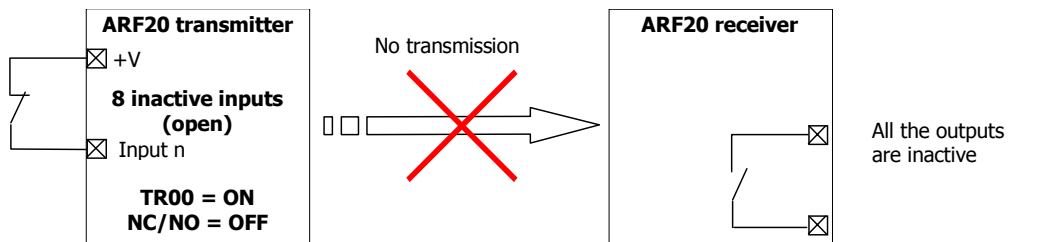
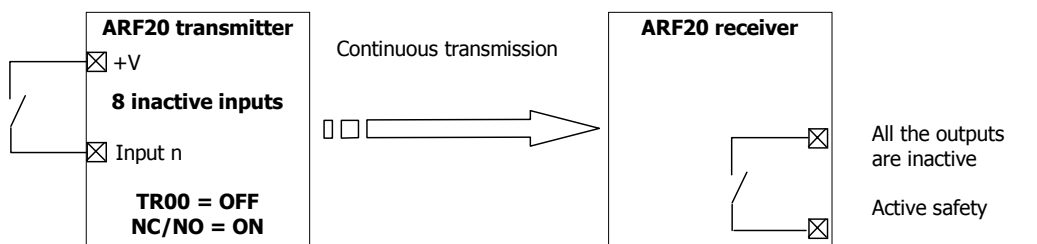
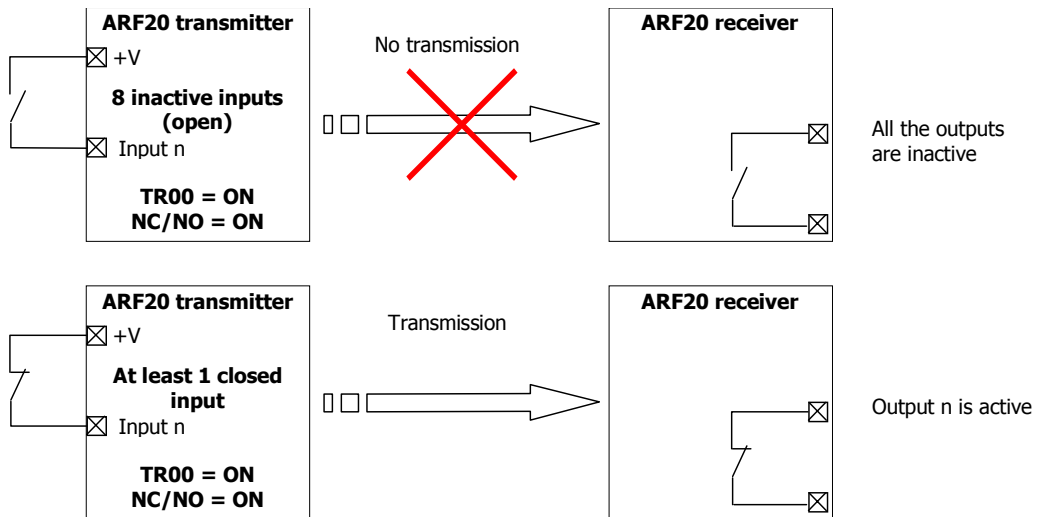

- 3-wire sensor connection

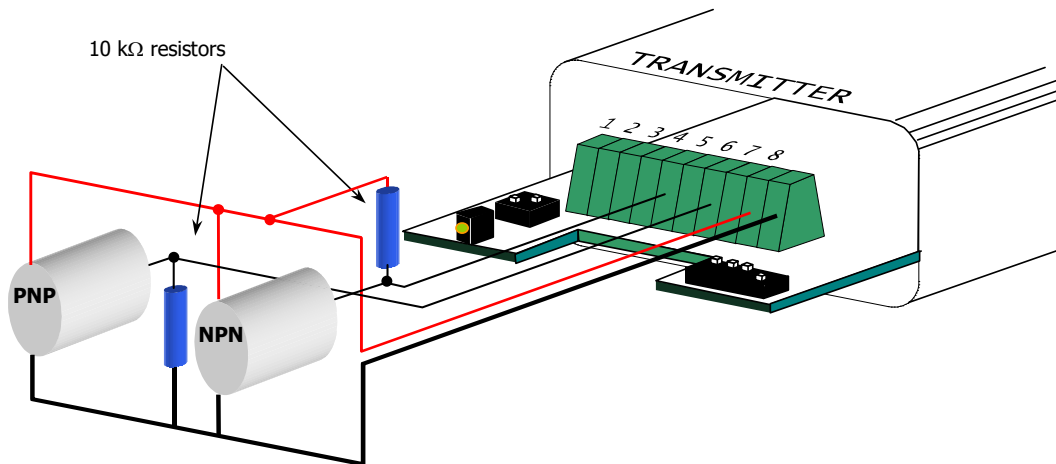

The sensors have the same power supply as the ARF20 transmitter.

For a PNP sensor, the product must be set to NO mode to transmit on presence detection.

For a NPN sensor, the product must be set to NC mode to transmit on presence detection.

- Dry contact connection.

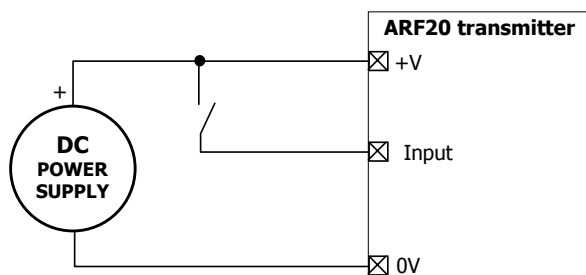

In NO mode closing of the contact triggers transmission which activates the corresponding output.  
 In NC mode it is opening of the contact which activates this output.

## ANTENNA WIRING

In daughter board version, an antenna has to be added to obtain correct communication between the products.

This antenna should be a wire with a length of  $\frac{1}{4}$  wave i.e. about 17 cm. This length is that which has to extend outside the housing if the latter is metallic.

This antenna can be located remotely by using a coaxial cable with its braid stripped over the last 17 centimetres.

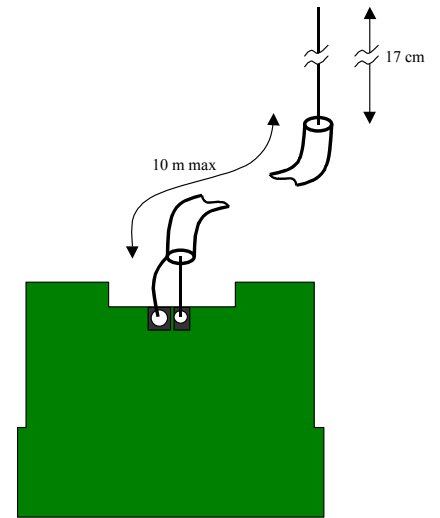

## OUTPUT WIRING

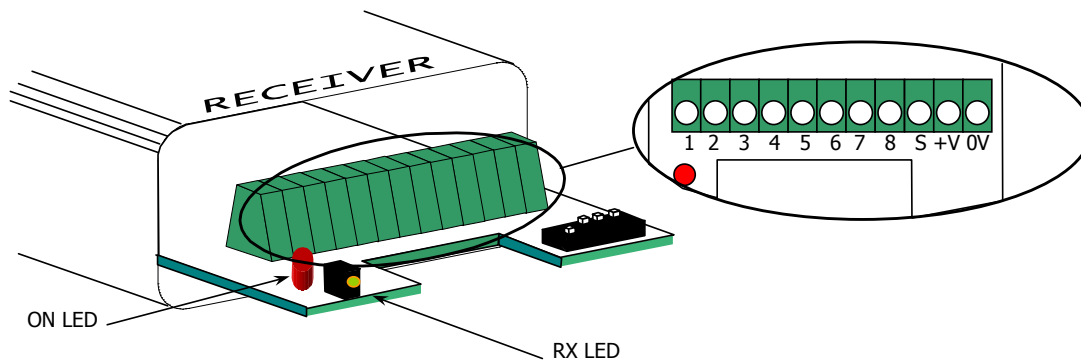

The outputs are wired on the receiver. They are of the **P open collector** type, i.e. when an output is active the voltage on the terminal block is that of the power supply. In other words an output acts like a switch one terminal of which is connected to the  $+V_{DC}$  and the other terminal being the output connector:

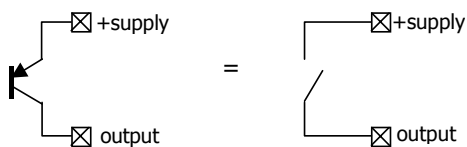

The receiver also has an output indicating data validity (S).

- Binary outputs

Output 1 copies the state of input 1, output 2 that of input 2, etc. On outputs 1 to 7 the maximum current absorbed is 100 mA. On output 8 this current increases to 1 A.

On the 4-relay receiver, the relays are the image of channels 1 to 4 when switch #5 (LH) is set to OFF, and the image of channels 5 to 8 when it is set to ON.

Relay wiring:

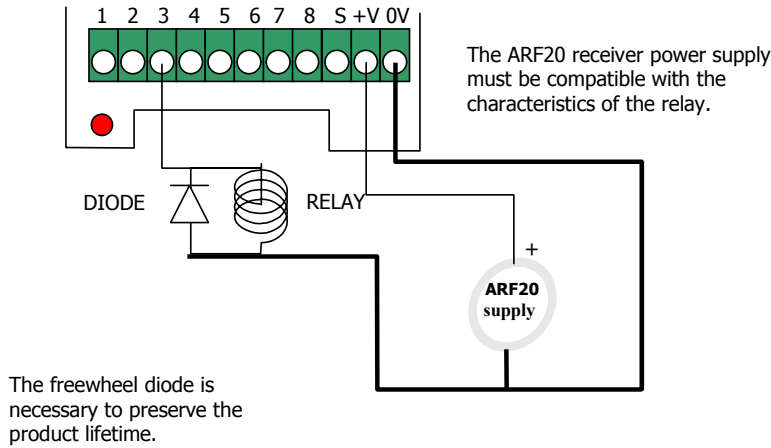

Wiring to a controller:

The ARF 20 receiver can be connected to an industrial programmable controller. An active channel sends a low level to the controller. On a negative input logic controller, reading of the channel will be direct, and on a positive input logic controller, reading of the channel will be inverted.

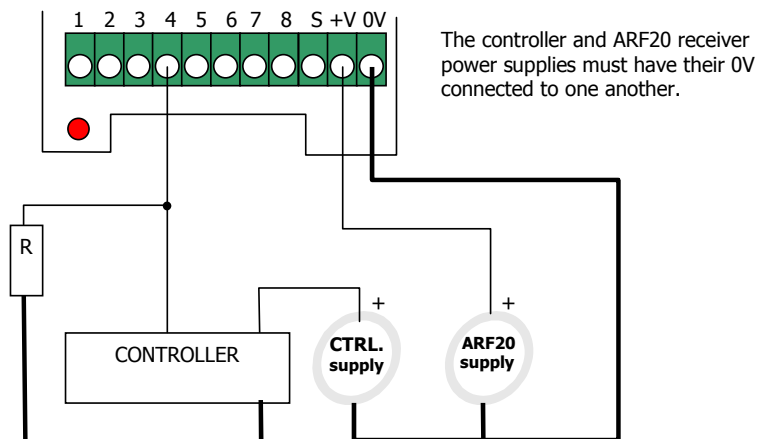

- Validity output on ARF6189

This is an **Open Collector** output marked S on the terminal block.

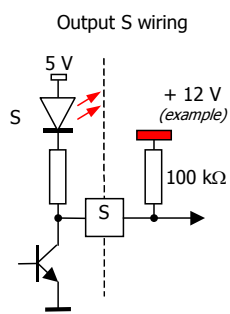

It is at 0V when the receiver is receiving correctly and at high level when receipt is bad. The red led furthest to the right, behind the terminal block, indicates the state of this output: On - receipt is correct, Off - no receipt.

It is not a linear output. This enables a zero output state due to absence of receipt to be differentiated from that due to no input activated.

- ① All receipts are correct, or only one is missing:  
The safety output remains inactive.

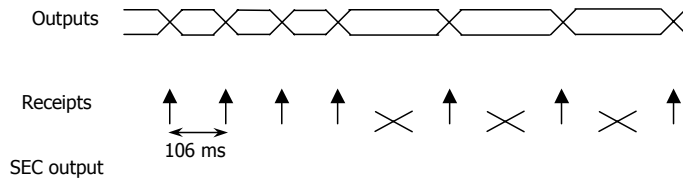

- ② Two consecutive receipts at least are missing:  
The safety output is activated.  
At the third missing receipt, the outputs become inactive.

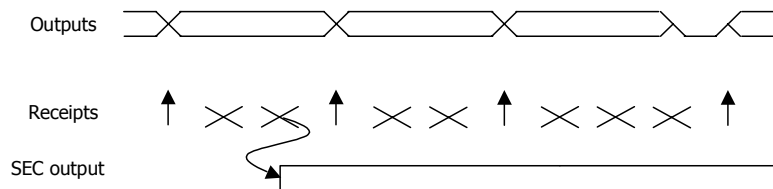

- **Relay output connection.**

The ARF6678 receiver is provided with 3 relays with a single NO contact and one relay with NO and NC contacts. These relays are designed to cut 12A in 250V.

These relays copy the state of the inputs of an ARF6188 transmitter after learning of this transmitter has been performed. Depending on the position of switch #5 the relays reproduce the state of inputs 1 to 4 (switch #5 on OFF) or the state of inputs 5 to 8 (switch #5 on ON).

NB: If relay 1 or 3 is used for the safety output, it no longer copies the associated input but its closing indicates the quality of the radio link.

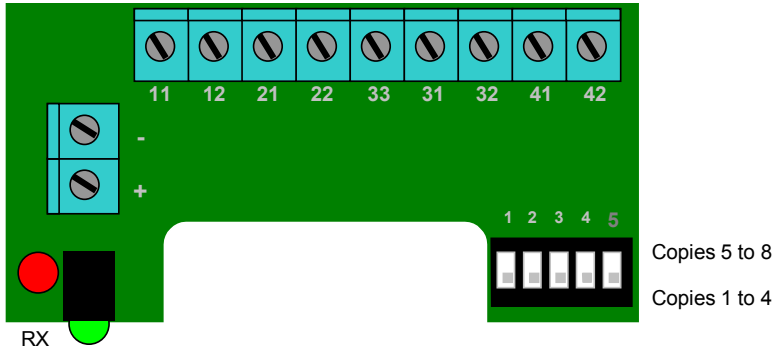

Wiring examples:

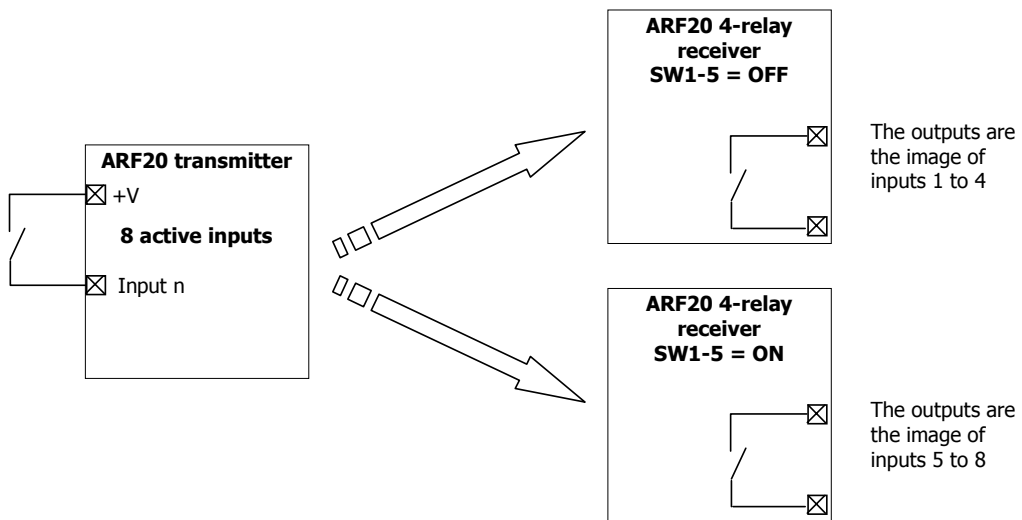
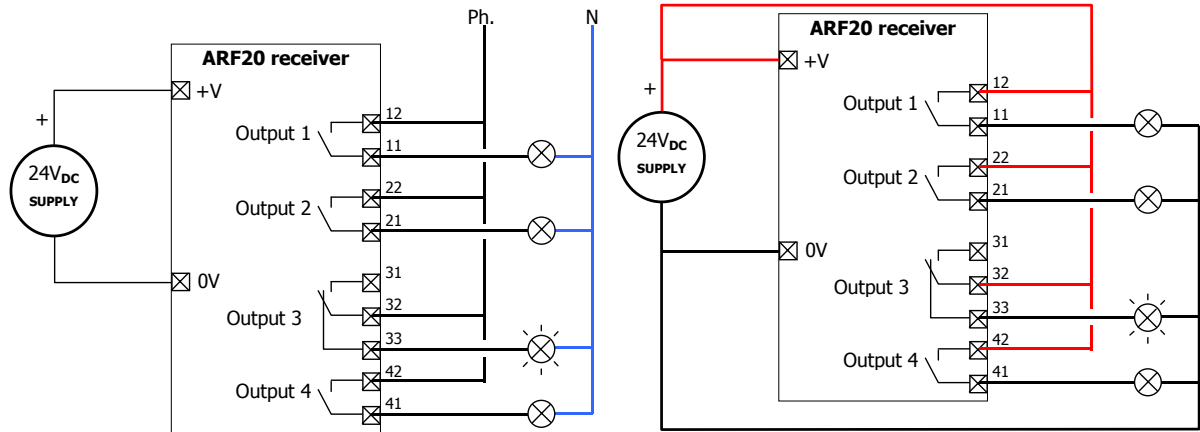

- Validity output on ARF6678

On this receiver the information is available as an option on a relay. This can be on relay 1 (NO) or relay 3 (NO/NC), as required.

#### SAFETY VALIDATION ON RELAY 1

- Set switch #1 to OFF (programming mode), then set switches #2 to 5 to OFF, and then move switches #4 (SE) and 5 (14) to ON.
- Reset switch #1 (N/P) to ON (normal mode) and set the next 3 switches (C1, C2, C3) to the same positions as those of the transmitter (ADD 1, 2 and 3).

#### SAFETY VALIDATION ON RELAY 3

- Set switch #1 to OFF (programming mode), then set switches #2 to 5 to OFF. Then move switch #4 (SE) to ON and switch #5 (14) to OFF.
- Reset switch #1 (N/P) to ON (normal mode) and set the next 3 switches (C1, C2, C3) to the same positions as those of the transmitter (ADD 1, 2 and 3).

#### SAFETY DISABLE

- Set switch #1 to OFF (programming mode), then set switches #2 to 5 to OFF. Then move switch #4 (SE) to OFF.
- Reset switch #1 (N/P) to ON (normal mode) and set the next 3 switches (C1, C2, C3) to the same positions as those of the transmitter (ADD 1, 2 and 3).

## SYNCHRO MODE

This mode enables two-way links to be achieved with 2 ARF20 pairs. In this case the return link is dependent on the outgoing link.

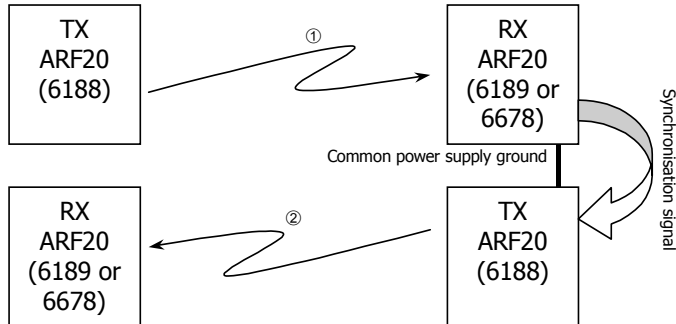

The link (2) only works if link (1) is present. Take care over transmission in rest state.

### Setting transmitter to synchro mode

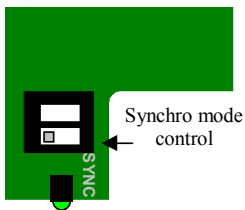

A transmitter is set to synchro mode by setting switch #2 marked SYNC to OFF.

Then connect the synchro output of the link (1) receiver (pad to be soldered marked "SYNC" / ARF6189 or "2" / ARF6678) to the TRIG input terminal of the link (2) receiver.

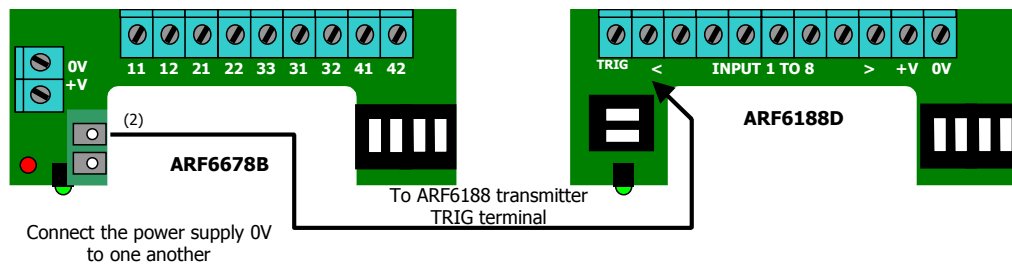
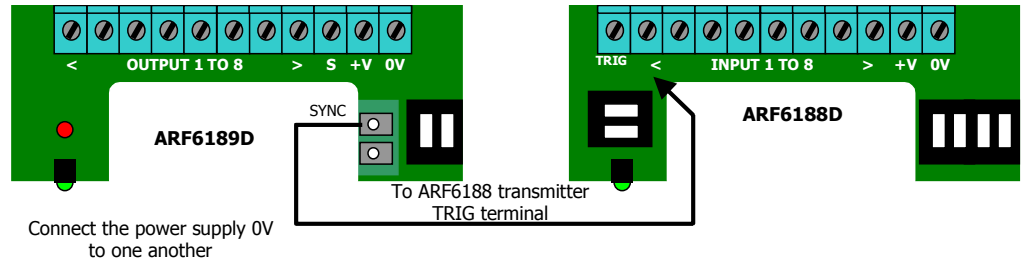

## SERIAL OUTPUT

The two ARF20 range receivers are equipped with a TTL format serial link output.  
The format is fixed: 9600 bauds / 8 bits, no parity 1 stop.

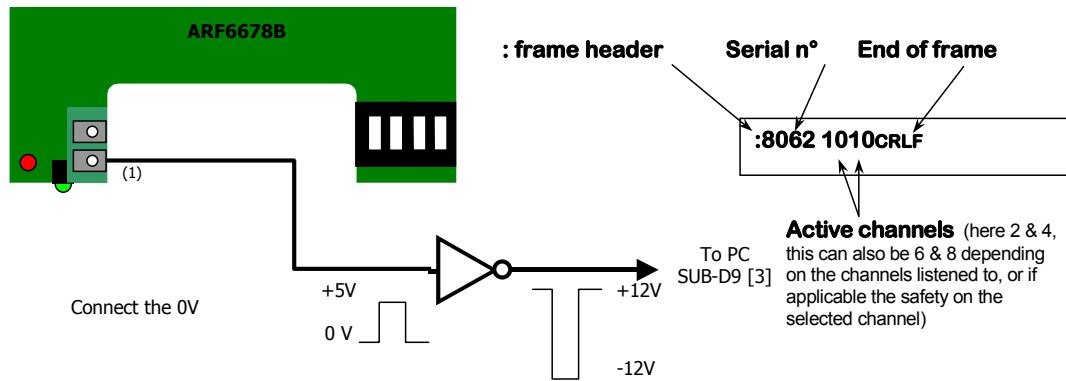
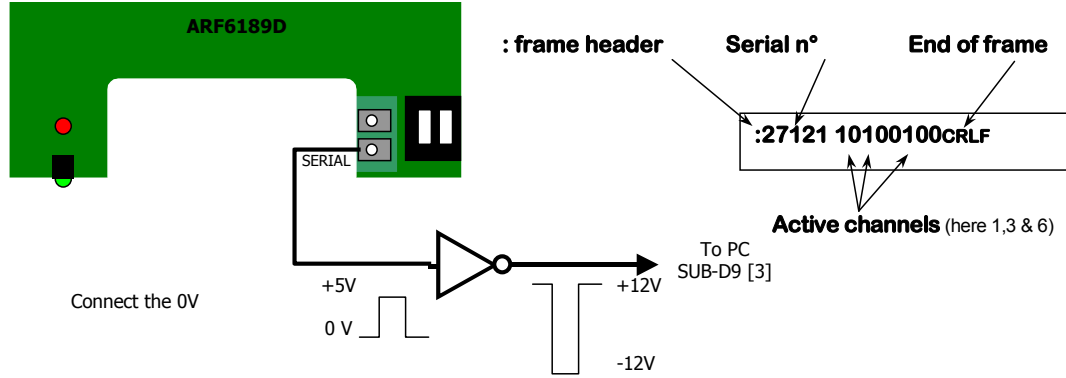

## BOARD DIMENSIONS

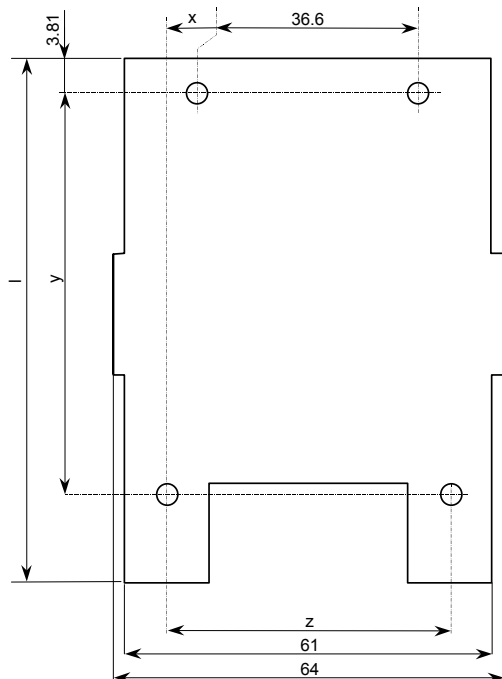

Copper	l	x	y	z
ARF6188	87	7.75	67.06	52.84
ARF6189	87	7.49	67.82	52.84
ARF6678	122	-6.6	105.3	23

## TECHNICAL DATA

- Operating temperature: -20°C to +70°C
- Communication channels:

ADDRESS	SW3	SW2	SW1	Low channel	Middle channel	High channel
1	ON	ON	OFF	2 (433.150)	23 (433.675)	46 (434.250)
2	ON	OFF	ON	5 (433.225)	26 (433.750)	49 (434.325)
3	ON	OFF	OFF	8 (433.300)	29 (433.825)	52 (434.400)
4	OFF	ON	ON	11 (433.375)	32 (433.900)	55 (434.475)
5	OFF	ON	OFF	14 (433.450)	35 (433.975)	58 (434.550)
6	OFF	OFF	ON	17 (433.525)	40 (434.100)	61 (434.625)
7	OFF	OFF	OFF	20 (433.600)	43 (434.175)	64 (434.700)
0	ON	ON	ON			

- **Transmitter**

- Power supply: 9 to 30 V<sub>DC</sub>
- Multi-channel between 433.125 MHz and 434.7 MHz.
- Power: 10 mW / 50 Ω.
- 8 dry contact inputs. Z<sub>in</sub> > 50 kΩ.
- Consumption: 30 mA.

- **Receivers**

- Multi-channel between 433.125 MHz and 434.7 MHz.
- Sensitivity: better than 1.2 μV.
- ARF6189: 8 open collector outputs: V<sub>CE</sub> max. 30 V.
  - ☞ Power supply: 9 to 30 V<sub>DC</sub>
  - ☞ Maximum absorbable current outputs 1 to 7: 100 mA
  - ☞ Maximum absorbable current output 8: 1 A.
  - ☞ Receipt validity output.
- ARF6678: 4 relay outputs: 10A / 250V.
  - ☞ Power supply: 15 to 30 V<sub>DC</sub>
  - ☞ NO contact on outputs 1, 2 or 4
  - ☞ NO/NC contacts on output 3
  - ☞ Receipt validity output: disabled, or on relay 1 or relay 3, as required.
- Consumption: 53 mA excluding output

- **Conversion**

- Refresh period: 106 ms. (up to 320 ms when establishing the link)

- **Dimensions**

- 6188B and 6189B IP65 chip: 104 x 300 x 35 mm
- 6678B IP65 chip: 104 x 335 x 35 mm
- Distance between fixing points 6188B and 6189B : 4 holes diam. 4 to 92 x 61 mm
- Distance between fixing points 6678B: 4 holes diam. 4 to 92 x 96 mm

- **References**

- ARF6188A: ARF20 transmitter, board version.
- ARF6188B: ARF20 transmitter in IP65 chip version.
- ARF6189A: 8 open collector ARF20 receiver, board version.
- ARF6189B: 8 open collector ARF20 receiver in IP65 chip version.
- ARF6678A: 4-relay ARF20 receiver, board version.
- ARF6678B: 4-relay ARF20 receiver in IP65 chip version.
- ARF03: Antenna kit for the ARF618xA and ARF6678A in board version.