

ARF29

ARF6921JE

User Guide



DECLARATION OF CONFORMITY	2
PRESENTATION	3
<i>User interface</i>	3
<i>Power supply</i>	3
<i>Standby</i>	4
<i>Transmit/Receive mode selection</i>	4
<i>Data to transmit / data received</i>	4
<i>Channel selection</i>	4
<i>Calibration</i>	6
<i>Transmitted power selection</i>	6
<i>BUSY output</i>	6
<i>Channel settling time (Cst)</i>	9
<i>RSSI output</i>	9
RECOMMANDATIONS FOR USE	10
<i>Bit encoding</i>	10
<i>Frame encoding</i>	10
<i>Integration</i>	10
SPECIFICATIONS	12
DIMENSIONS	13
COMPLIANCE WITH REGULATIONS	13
REFERENCES	13

DECLARATION OF CONFORMITY

according to ISO/IEC Guide 22 and EN45014



Manufacturer's name: **ADEUNIS R.F.**

Manufacturer's address: Parc technologique PRE ROUX IV
283 rue Louis NEEL
38920 CROLLES - FRANCE

declares that the product

Product Name: **915 MHz FSK Transceiver Module**
Product Number(s): **ARF6921J**

Product options:

conforms to the FCC Part 15.247

Crolles, June 14th, 2006

VINCENT Hervé / Quality manager

PRESENTATION

The ARF29 range comprises one transceiver in the 915 MHz band with a transmission power of 500 mW. This transceiver enables connections to be established over several kilometers.

The ARF29 915 MHz is available in 1 version:

- ARF6921Jx : 75 channels at 4.8 kBps Manchester (4.8 kHz).

- User interface

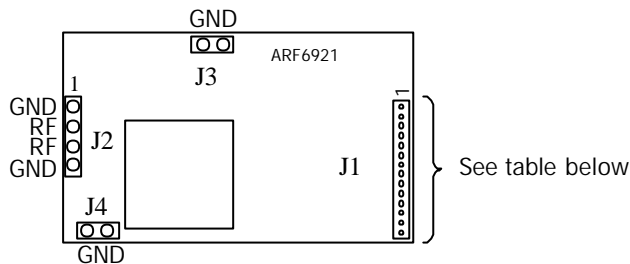

Connectors	Ref. No.	Name	Direction	Function
J1	1, 14	GND	Power supply	
	2	POWER DOWN	Input	Module in standby
	3	BUSY	Output	Indicates module not available
	4	TX/RX	Input	Transmit/Receive mode selection
	5	P1	Input	Power level select
	6	TXD	Input	Data to transmit
	7	P0	Input	Power level select
	8	VCC	Power supply	Power supply input
	9	C2	Input	SPI Data MOSI
	10	RXD	Output	Data received
	11	C1	Input	SPI Clock CLK
	12	RSSI	Output	Indicates RF level received
	13	C0	Input	SPI Chip Select CS
J2	1, 4	GND		
	2, 3	RF		RF output/Module antenna

- Power supply

The ARF29 transceiver supply voltage should be chosen in the 3.3V - 5V range and applied between pin 8 and pins 1 and 14 of the connector.

The power supply source must be able to provide a current of 700 mA. This capacity can be reduced to 40 mA if the module is used on receipt only.

NB : - Take care! Choose a power supply able to withstand the load variations due to mode changes (Receipt to transmission for example....)

- All the module GND connections must be connected to the motherboard.

- Standby

This mode enables to limit the consumption to around 830uA.

Take care! This consumption assumes that the inputs C1, C2, P1 and P2 are OFF. If one of these inputs is activated (ON), 130uA have to be added. Consequently, if the 4 inputs are on ON, the standby current consumption increases to about 1.35mA.

In this mode the module does not receive and does not supply information to the outside.

- Power_down = 0V : normal mode
- Power_down = VCC : standby mode

- Transmit/Receive mode selection

The TX/RX input enables the transceiver to be set to transmission or receipt. Switching from one mode to the other is not instantaneous. See the different switching times in paragraph 4.

- TX / RX = 0V : module in receipt mode
- TX / RX = VCC : module in transmission mode

- Data to transmit / data received

By default, this module operates **in transparent mode**. The frame definition and bit coding/decoding operations are taken charge of by the associated logic.

The data to be transmitted or delivered should be in the form of a digital signal between 0 and VCC. The ARF29 module does not process analog data.

- The data to be transmitted are to be supplied on the TXD pin
- The data received are available on the RXD pin

- Channel selection

The choice of channel is performed by using the SPI bus on C0 to C2. Command byte is sent on this bus to select a particular channel and performs a recalibration (VCO and PLL adjustment) of the transceiver if necessary. By default, the channel selected at power-up is channel 1 and the transceiver is calibrated.

The channel selection allows to select a new channel and to recalibrate the transceiver. It is the responsibility of the application to select a “new channel + recalibration” if the step from the last selected channel is greater than 1MHz

The byte to send on SPI bus is the channel number to select (from 01 to 75 – 01h to 4Bh). If a recalibration is required, the MSB bit (bit 7) must be set to 1 (from 81h to select channel 1 and recalibrate the transceiver to CBh to select channel 75 + recalibration).

The byte is sent MSB first on the bus. Bits are sampled on high state by the module. The SPI on the module acts as a slave and must be drive by an external master.

The channel setting time is 1280 μ s in Tx mode, 980 μ s in Rx (time without recalibration). When a calibration is required by setting bit 7, these times varies from 14 ms to 35 ms in Tx mode and from 22 ms to 35 ms in Rx mode with a typical duration of 24ms. During the whole channel setting period (with or without calibration), the BUSY line is held low and the Power

Amplifier (in Tx mode) of the transceiver is OFF. Refer to BUSY section for detailed timing of channel setting time.

It is important to note that the requested action is only started when the BUSY line becomes active (low state). While BUSY is high, no changes are performed on the module. This allows the external logic to transmit or receive data during the whole SPI time: We recommend to stops radio transfer on the rising edge of chip select.

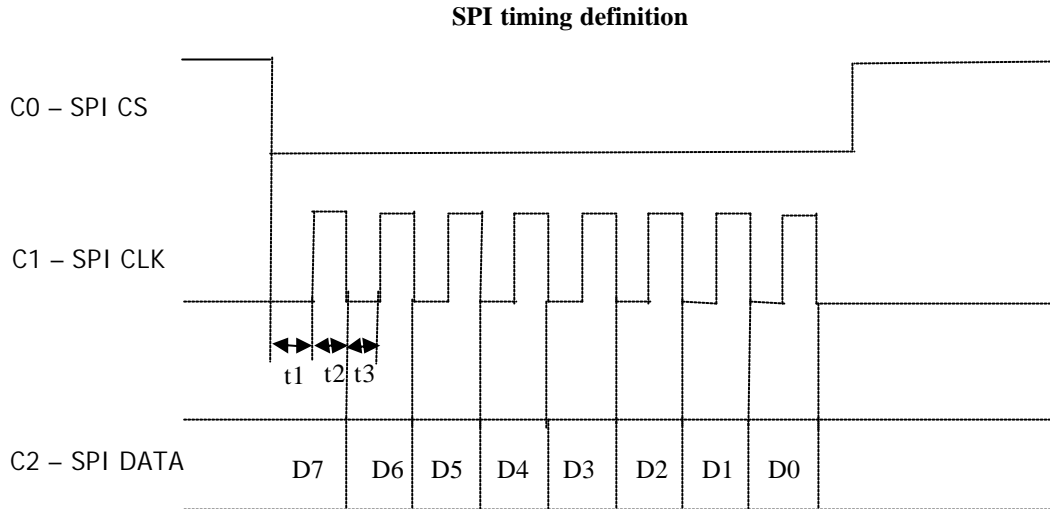

- t1 – SPI CLK low state duration from CS activation. $t1 \geq 250\mu s$
- t2 – SPI CLK high state duration min time. $t2 \geq 250\mu s$ (F SPI max is 2kHz)
- t3 – SPI CLK low state duration min time. $t3 \geq 250\mu s$ (F SPI max is 2kHz)

Data must be set on falling edge by the master. Data are sampled on high state by the module and must be valid during the whole high state.

A new SPI cycle or any I/O command of the module can be initiated or used only when the previous request has been processed. The BUSY signal is activated during command processing. The BUSY timings are defined in the BUSY Output section. Each byte transfer requires the activation deactivation of CS.

ARF6921Jx - 75 channels

Channel	Frequency (Mhz)
1	915,50
2	915,55
3	915,60
4	915,65
5	915,70
6	915,75
7	915,80
8	915,85
9	915,90
10	915,95
11	916,00
12	916,05
13	916,10
14	916,15
15	916,20
16	916,25
17	916,30
18	916,35

Channel	Frequency (Mhz)
26	916,75
27	916,80
28	916,85
29	916,90
30	916,95
31	917,00
32	917,05
33	917,10
34	917,15
35	917,20
36	917,25
37	917,30
38	917,35
39	917,40
40	917,45
41	917,50
42	917,55
43	917,60

Channel	Frequency (Mhz)
51	918,00
52	918,05
53	918,10
54	918,15
55	918,20
56	918,25
57	918,30
58	918,35
59	918,40
60	918,45
61	918,50
62	918,55
63	918,60
64	918,65
65	918,70
66	918,75
67	918,80
68	918,85

19	916,40
20	916,45
21	916,50
22	916,55
23	916,60
24	916,65
25	916,70

44	917,65
45	917,70
46	917,75
47	917,80
48	917,85
49	917,90
50	917,95

69	918,90
70	918,95
71	919,00
72	919,05
73	919,10
74	919,15
75	919,20

- **Calibration**

The transceiver calibration (VCO and PLL adjustment) is performed once at startup. After this initial calibration, no more calibration is performed (except calibrations perform with channel selection command) by the module and it is the responsibility of external logic to recalibrate the chip. A recalibration must be performed on the following events:

- on temperature variation > 20°C
- on power supply variations >100mV
- on channel selection (when the channel spacing between the old channel and the new one is > 1MHz)

The calibration is performed by sending a data byte equal to 0 on the SPI bus. The calibration time can reach up to 32 ms. The typical time is about 22 ms. During the whole calibration phase, the BUSY line is held low. The BUSY timings are defined in the BUSY output section.

- **Transmitted power selection**

The two inputs P0 and P1 enable the transmission power to be adjusted and the consumption to be reduced.

P0	P1	Power
ON	ON	+18 dBm (60mW)
ON	OFF	+21dBm (125mW)
OFF	ON	+24 dBm (250mW)
OFF	OFF	+27dBm (500mW)

Only OFF/OFF mode (maximum power) is guaranteed. The levels of the other modes are given for indication purposes only. At each power step, the consumption gain is about 100mA as compared with the higher level.

- **BUSY output**

This output indicates by a level that the module is unavailable to transmit or receive. This occurs momentarily when changing mode (e. g. switching from TX to RX, power-up, standby mode exit, channel selection etc.) and when calibrations are performed.

The data received or transmitted when the BUSY signal is at low level are non significant or not transmitted.

Switching from transmission / receipt:

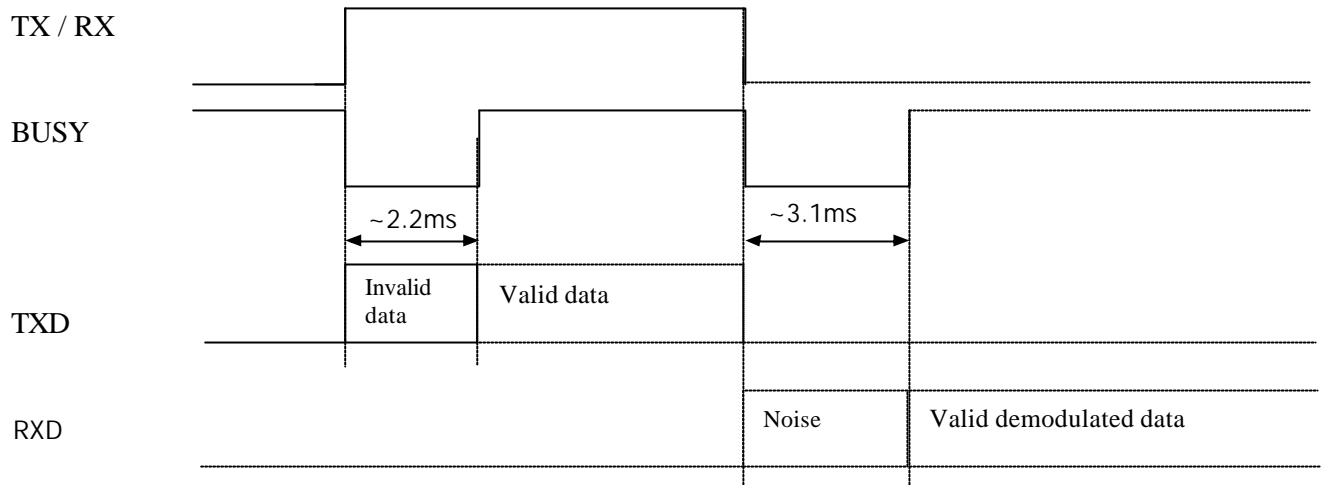

Switching from standby / transmission

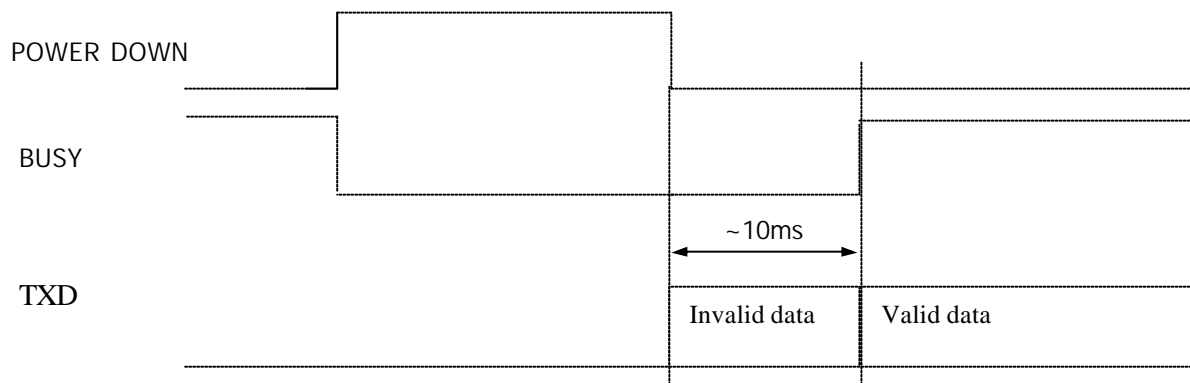

Note : the BUSY time can reach up to 28ms

Switching from standby / receipt:

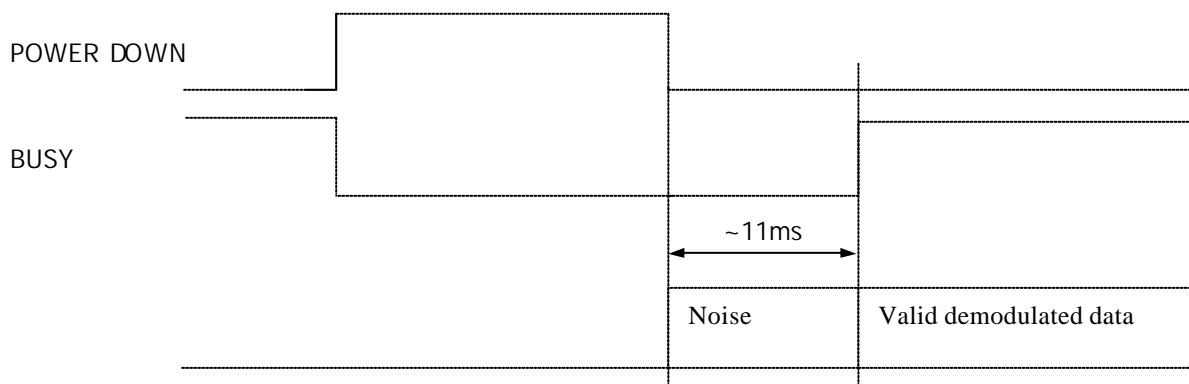

Note: the BUSY time can reach up to 28ms

Calibration:

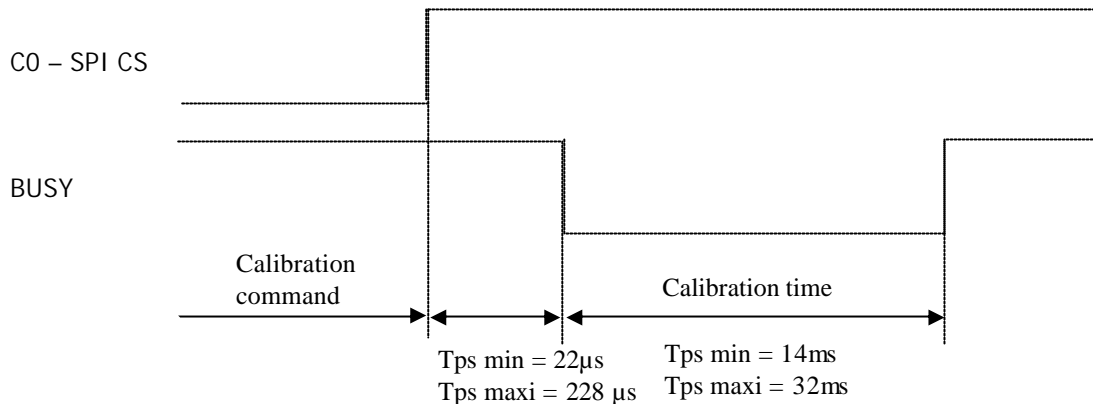

Channel setting:

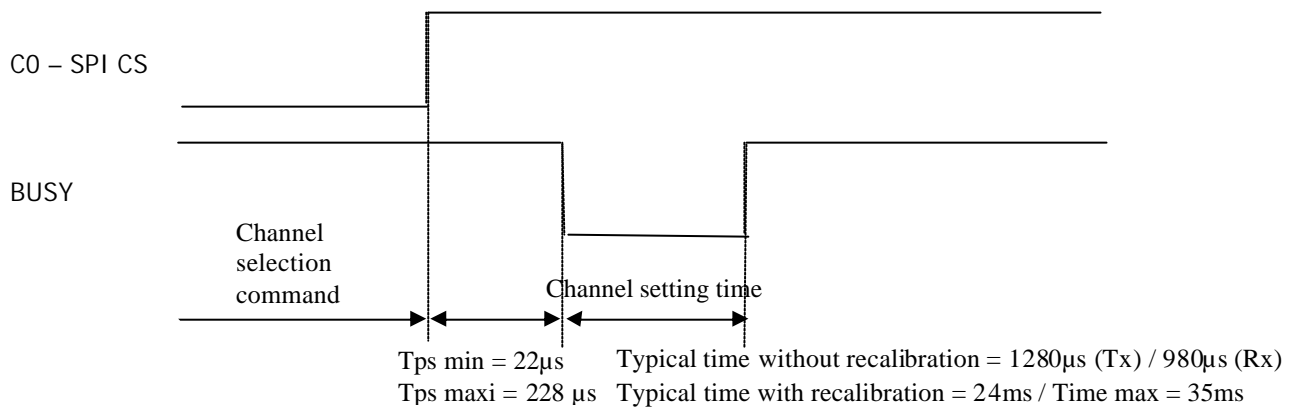

RXD

Power up :

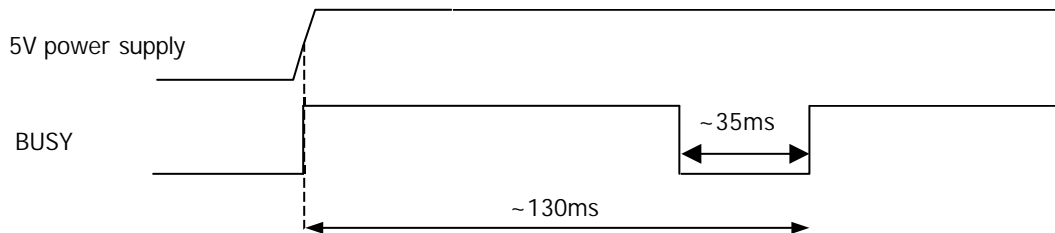

NB : On Power-up:

- The module is unavailable for 130ms. It is therefore necessary to wait until the end of the pulse on the Busy signal to consider the module available.
- **ON START-UP**: The BUSY pin is considered as an input by the module. This pin **MUST** therefore be left OFF on power-up.

- Channel settling time (Cst)

This characteristic corresponds to the time required to obtain the first valid bits on receipt on an ARF29 n°2 (RXD2) on continuous listening after transmission of a frame from another remote ARF29 n°1 module (TXD1).

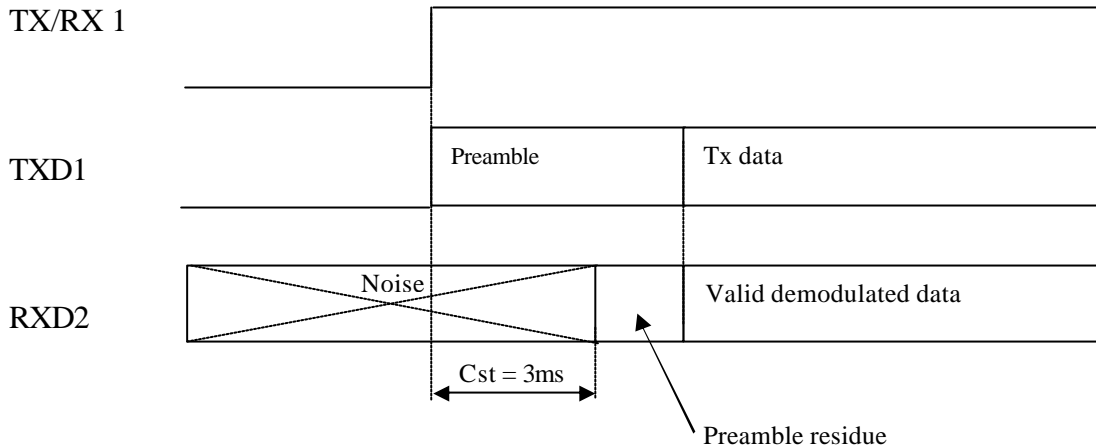

- RSSI output

The RSSI signal gives an **indication** of the power received. It is an analog output whose mean value varies linearly with the power received.

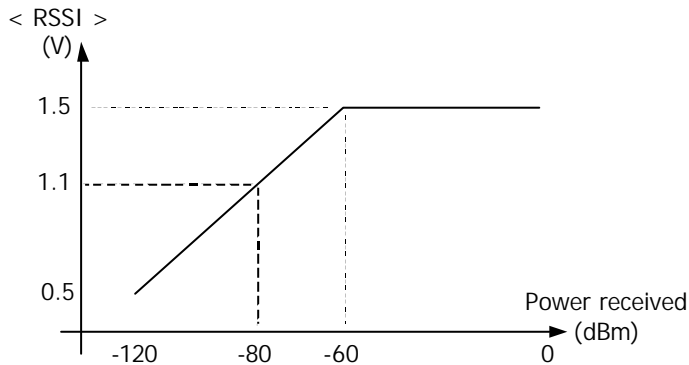

Take care:

- The RSSI information must not be used to wake up the receiver in applications where range and therefore maximum sensitivity are sought for.
- The RSSI level remains an indicator which must be used with precaution due to dispersions between components.

The curve presented above may therefore be subject to slight changes from one product to the other. These dispersions are also strongly linked to the temperature of use of the ARF29.

- The RSSI level can also indicate the presence of a possible jammer in the channel used. Simply examining the RSSI does not therefore enable detection of a useful signal from a remote transmitter to be ensured. The identity of the transmitter also has to be checked by analyzing the frames received.

RSSI is a necessary but not sufficient condition to achieve correct receipt.

RECOMMENDATIONS FOR USE

- **Bit encoding**

In the case of radio transmission, it is preferable to limit the spectrum of the signals to be transmitted as far as possible, in particular towards low frequencies, even if this involves increasing the main frequency. In addition, it is advantageous to reset the synchronization on each bit transmitted; the receivers are in fact the cause of large duty cycle errors on the electrical states.

Bit encoding of Manchester (or Biphas) type should therefore be preferred, as described below:

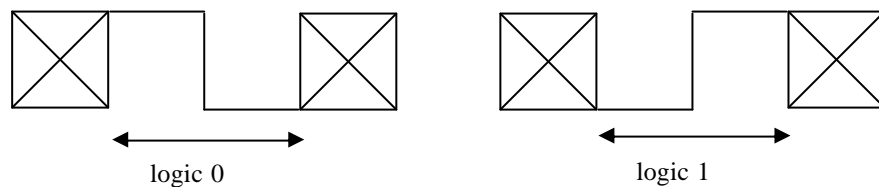

- **Frame encoding**

Once the bits have been encoded, it is then imperative to transmit them according to a frame structure; the radio link is very sensitive to binary flow breaks which only byte "serialization" can minimize.

A conventional frame structure is set out below:

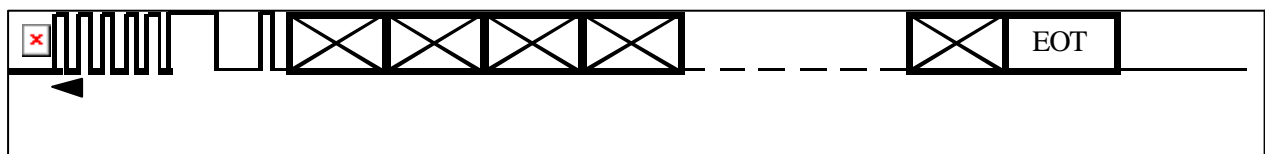

- 1 **Preamble** : Electrical succession 101010... designed to fix the receiver polarizations and compensate the channel settling time.
- 2 **Start pattern**: Electrical pattern which marks the start of the useful data by a break in the binary flow of the preamble.
- 3 **Useful part**: Successions of bytes encoded at bit level.
- 4 **Stop pattern**: Indicates the end of the frame (necessary when the frame can be of variable length).

- **Integration**

Daughter board:

- The signals of the different electrical accesses are given in the “user interface” part of this document. The "Low Frequency" pins (connector J1) can be connected on the

motherboard by means of a 1.27mm pitch strip. For the J2, J3 and J4 connectors, 2.54mm pitch strips (HE14 type) should be used.

- The motherboard can be used to locate the antenna output by means of a 50 Ohm printed line. This line is formed by a printed track 2.5 mm wide which must be situated above the continuous ground plane (the HF cold point should be connected as short as possible to this plane). Avoid running close to the digital lines!

EMC aspect:

- When integrating a radio element in an electronic system, the motherboard must have a ground plane as continuous as possible. The GND signals from the module should be connected as short as possible to this plane. It is preferable for the module to then be mounted on the ground plane side, opposite the tracks.
- A receiver without a mute generates output noise in the absence of a receipt signal. This does not mean that it is polluted by a disturber - the data will be "clear" on receipt.
- Take care! The presence of a mobile phone near the receiver may disturb long distance transmissions.

SPECIFICATIONS

	Parameter	Value	Conditions
Transmitter (Tx)	Maximum power	500mW (+27dBm)	In 50 Ohms
	Modulation	FSK +/-5kHz	
	Consumption	650 mA	- @max power - in 50 Ohms - @5V
	Wake-up time	10ms	From Power_Down mode
	Rx to Tx turn-around time	2ms	
Receiver (Rx)	Sensitivity	-110 dBm (0.7uV)	
	Passband @3dB	20 kHz	
	Consumption	25 mA	
	Wake-up time	10 ms	From Power_Down mode
	Rx to Tx wake-up time	3 ms	
Transceiver	VCC power supply	From 3.3V to 5V	
	Transmission rate	4.8 kBps Manchester i.e. 4.8kHz	
	Digital input/output	0/VCC	
	Standby consumption	830μA	Take care over the position of C1, C2, P1 and P2
	Channel settling time	3 ms	
	Free field range	6 km	
	Temperature	From -20°C to +70°C	
	Dimensions	30.5 x 50.8 x 12	in mm
	Standards	FCC Part 15.247	

DIMENSIONS

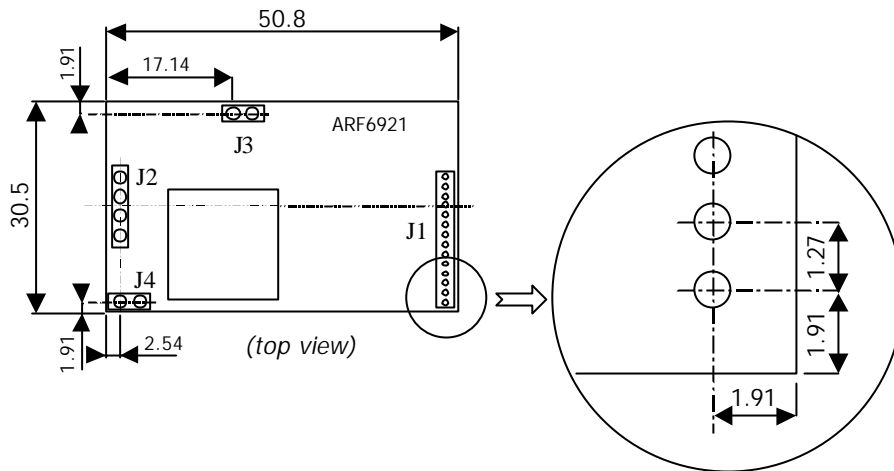

- The dimensions are given in mm.
- The connectors are not supplied with the module.
- J1 has a pitch of 1.27mm and J2, J3 and J4 a pitch of 2.54 mm.

COMPLIANCE WITH REGULATIONS

When using radio transceivers in the form of integrated daughter boards, conformity with regulation compliance relates to the finished product.

Important :

Although the ARF29 daughter boards comply with the criteria and dimensions of the FCC Part 15.247 radio standard, their integration in a “mother” electronic system may modify some electrical characteristics (harmonic levels, spurious RF, etc.)

Before it is sent for laboratory tests, the product therefore has to be examined on our premises to check that it complies with regulations. After presentation, the product and the test reports must be kept as proof of conformity.

REFERENCES

- ARF6921J : Transceiver – 75-channel – transmission rate 4.8 kbps Manchester