

A^{RF32} Bluetooth® Audio Modules



User Guide

No part of this document may be reproduced or transmitted (in electronic or paper version, photocopy) without Adeunis RF consent.

This document is subject to change without notice.

All trademarks mentioned in this guide are the property of their respective owner.

ADEUNIS RF

283, rue Louis Néel

38920 Crolles

France

Phone +33 (0)4 76 92 07 77

Fax +33 (0)4 76 08 97 46

Ref. 08-04-V7-pcy

Table of Contents

About this Document	2
Declaration of Conformity	3
Overview.....	4
Hardware essentials	5
Pin-out	6
Data Interface.....	7
Pin-out	8
Audio Interface	9
Audio gains adjustment	9
Audio gains adjustment	10
Footprint.....	12
Recommended exclusion zone around antenna	12
Software management	13
Non Volatile Default Settings.....	13
Operating modes.....	14
Setting up an direct AUDIO link over SCO/SPP between two ARF32 modules	16
Advanced commands.....	18
Setting up “handsfree”, “headset audio gateway” or “headset” using Bluetooth Audio profiles	19
Acting as HANDSFREE Audio Gateway	19
Using full HEADSET profile.....	20
Acting as HEADSET Audio Gateway HSAG.....	21
Acting as HEADSET HS	23
Specifications.....	25
ARF7213 DemoKit schematic.....	27
Annex 1 : Firmware and document updates	28

About this Document

This guide describes the A^{RF32} devices, their options and accessories.

Declaration of Conformity



Manufacturer's name: **ADEUNIS R.F.**
 Manufacturer's address: Parc Technologique PRE ROUX IV
 283 rue Louis NEEL
 38920 CROLLES - FRANCE

declares that the product if used and installed according to the user guide available on our web site www.adeunis-rf.com

Product Name: **ARF32**
 Product Number(s): **ARF7208A & ARF7208D**
 is designed to comply with the RTTE Directive 99/5/EC:
 EMC: according to the harmonized standard EN 301 489.
 Safety: according to the standard EN 60950-1/2001
 Radio: according to harmonized standard EN 300-328 covering essential radio requirements of the RTTE directive.
 Notes: - Conformity has been evaluated according to the procedure described in Annex III of the RTTE directive.
 - Receiver class (if applicable): 3.

According to the 1999/519/EC recommendation, minimum distance between the product and the body could be required depending on the module integration.

Warning: - CE marking applies only to End Products: Because this equipment is only a subassembly, conformity testing has been reduced (equipment has been design in accordance to standards but full testing is impossible). Manufacturer of End Products, based on such a solution, has to insure full conformity to be able to CE label marking.

- As the integration of a radio module requires wireless technological knowledge, ADEUNIS RF proposes its technical proficiency to its customers for a pre-compliance qualification of end products. In case of no-conformity, ADEUNIS RF will not be held back responsible if this stage has not been realised.

Crolles, November 6th, 2007
 VINCENT Hervé / Quality manager

Download of the user guide

Thank you for having chosen the ADEUNIS RF products.
 User guides can be uploaded directly on our web site www.adeunis-rf.com

Index **Products**
 Paragraph **OEM Modules > Bluetooth® Module**

Print version available upon request

- ✓ Tel : +33 4 76 92 07 77
- ✓ Email : arf@adeunis-rf.com

Overview

The A^{RF32} module full complies with the V2.0 Bluetooth® standard and data rate goes up to 723 kbps. Data exchanges and set-up are only done through an UART data port, under SPP profile. Miniature antenna is integrated. Audio uses PCM SCO with integrated (or not) CODEC under HFP Handsfree and HSP Headset or Audio gateway profiles.

A^{RF32} module is usable as “Audio Gateway” to directly connect to standard BT headsets or as “Hand Free” or “Headset” if microphone & earphone are added.

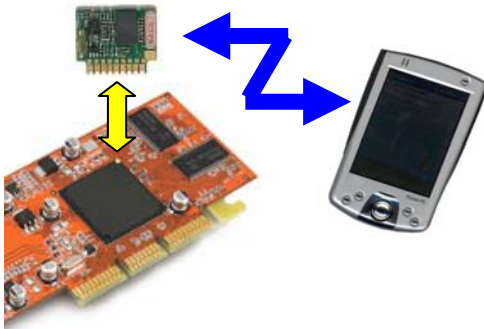

A^{RF32} can be used under two modes :

Classical Bluetooth® mode : Master starts with GAP identification, then, SDAP profile review, SPP connection and transparent communication.

Automatic Bluetooth® mode : Identification, profile review and connection to 1 to 3 known slaves are recorded by the master. After booting, Bluetooth® link is directly open in transparent mode.

ARF32 modules are available as stand-alone ARF7208 data/audio module or in the ARF7213 data/audio demo kit. This demo kit can be fully set-up and used with the National Semiconductors® “Simply Blue Commander” Software.

Hardware essentials

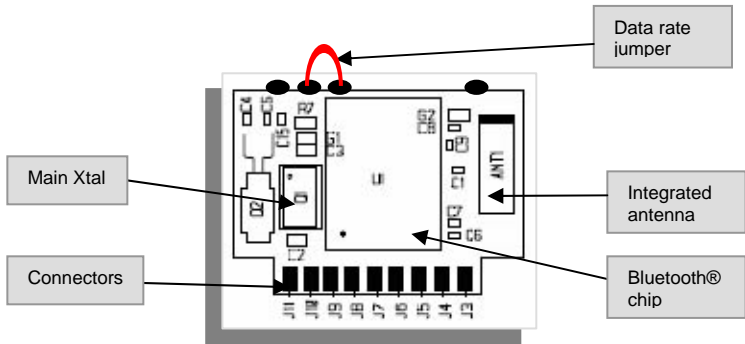

PCB top face : Bluetooth® transceiver and antenna

The purpose of the “Data Rate Jumper” is to be able to access the ARF32 module by forcing the UART data rate in case of bad “Non Volatile Settings” programming during test and evaluation.

In case of set-up error while evaluating, communication with ARF32 module can be lost (bad UART parameter set-up).

By adding the “Data Rate Jumper”, UART settings are forced to:

- Data rate = 9600 bps

NB : Other settings (Parity, Stop bit & flow control...) remain the same and have to be check for recovery values.

It becomes possible to re-program the “Non volatile Settings” to access again the ARF32 Module. When done, jumper can be removed.

Pin-out

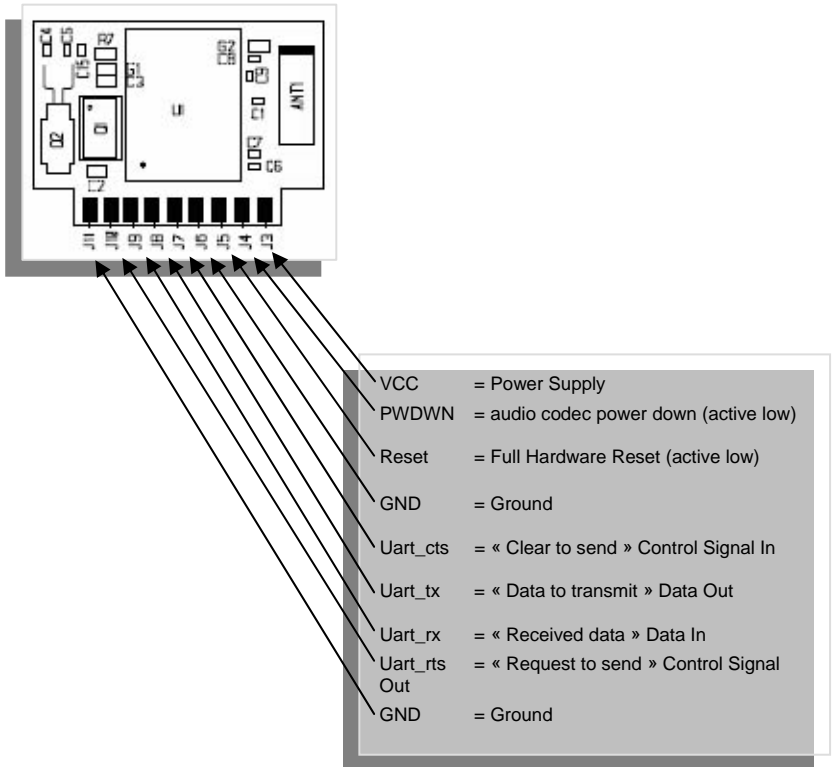

Data Interface

Signal	I/O	Designation	Comment
VCC	I	Main power supply	$2.85 < VCC < 3.6 \text{ V}$ and $I < 65 \text{ mA}$
PWDWN	I	Audio codec power down	Active low. Must be used with Bluetooth [®] low power modes to reduce the total consumption.
Reset	I	Hardware reset	ARF32 reset when Low
Uart_cts	I	Clear to send Signal	Serial port Flow control Input (MUST BE USED)
Uart_tx	O	Data to transmit	Serial port Data Output (0/Vcc level)
Uart_rx	I	Received data	Serial port Data Input (0/Vcc level)
Uart_rts	O	Request to send Signal	Serial port Flow control Output (MUST BE USED)
GND	-	Common Ground	Connected to motherboard ground plane

NOTE

For all I/Os : $0.7 \times VCC$
- 0.5 V

< Logical 1 < $VCC + 0.5 \text{ V}$
< Logical 0 < $0.3 \times VCC$

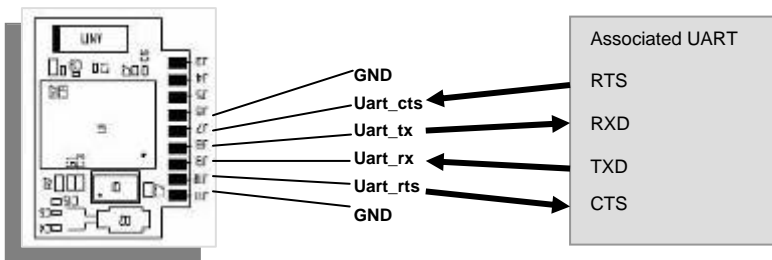

PCB bottom face: Audio codec

Pin-out

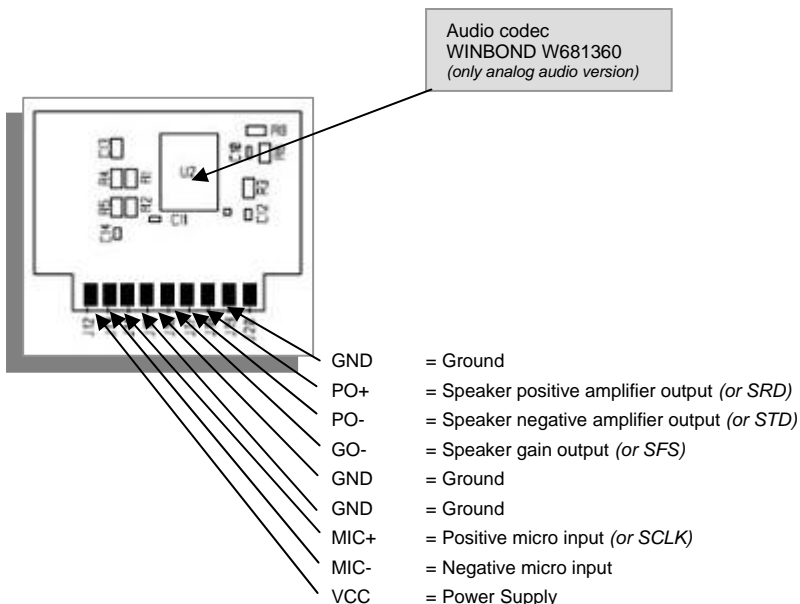

NOTES

Italic mentions are for Audio Digital Version (ie Direct PCM – See LMX9830 datasheet)

Audio Interface

Signal	I/O	Designation	Comment
GND	-	Common Ground	Connected to motherboard ground plane
PO+	O (I)	Speaker positive amplifier output (or <i>SRD</i> = PCM data received input)	See "Antenna exclusion zone"
PO-	O (O)	Speaker negative amplifier output (or <i>STD</i> = PCM data transmitted output)	See "Antenna exclusion zone"
GO-	O (I/O)	Speaker gain output (or <i>SFS</i> = PCM frame synchronization)	See "Antenna exclusion zone"
GND	-	Common Ground	Connected to motherboard ground plane
GND	-	Common Ground	Connected to motherboard ground plane
MIC+	I (I/O)	Positive micro input (or <i>SCLK</i> = PCM interface clock)	See "Antenna exclusion zone"
MIC-	I	Negative micro input	See "Antenna exclusion zone"
VCC	I	Main power supply	2.85 < VCC < 3.6 V and I < 65 mA Typically 3V.

NOTES

Italic mentions are for Audio Digital Version (ie Direct PCM – See LMX9830 datasheet)

Audio gains adjustment

Introduction

The input and output audio gains must be adjusted according to the micro, speaker or audio I/Os levels used.

The audio codec WINBOND W681360 integrates one amplifier for the mic gain and a second one for the speaker. (Download the datasheet for more information.)

Several passive components are around the amplifiers. Most are mounted on the module around the audio codec. Others **must** be added on motherboard in order to fix input and output gains.

Input gain:

The schematic below shows the analog audio input diagram.

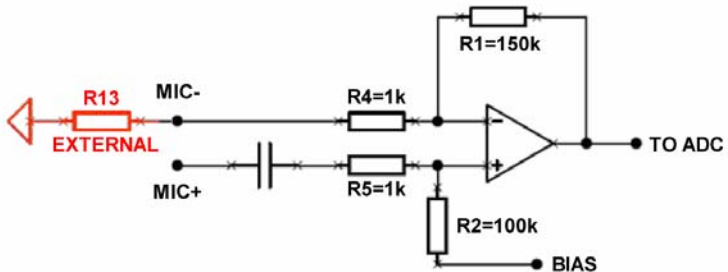

In red is the external resistor usable to adjust input operating audio level. Some examples:

If $R13 = 0$	$G = 150$	-Few mV: Typ Electret Mic input-
If $R13 = 150k$	$G = 2$	-Few 100mV: Typ Line input-

NOTES

"TO ADC" max $\leq 2V$ peak to peak.

Electret mic polarisation has to be external (not shown on schem)

Possible balanced input using MIC+ & MIC-

Output gain:

The schematic below shows the analog audio output diagram.

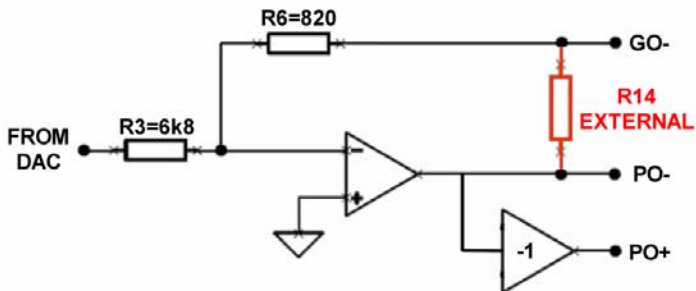

In red is the external resistor usable to adjust output operating audio level. Some examples:

If $R14 = 0$	$G = 0.12$	-Few 100mV: Typ Earphone output-
If $R14 = 4.7k$	$G = 0.8$	-Close to 1V: Typ Line output-

NOTES

"FROM DAC" typ about 2V peak to peak.
Possible bridged balanced output using PO+ & PO-



Footprint

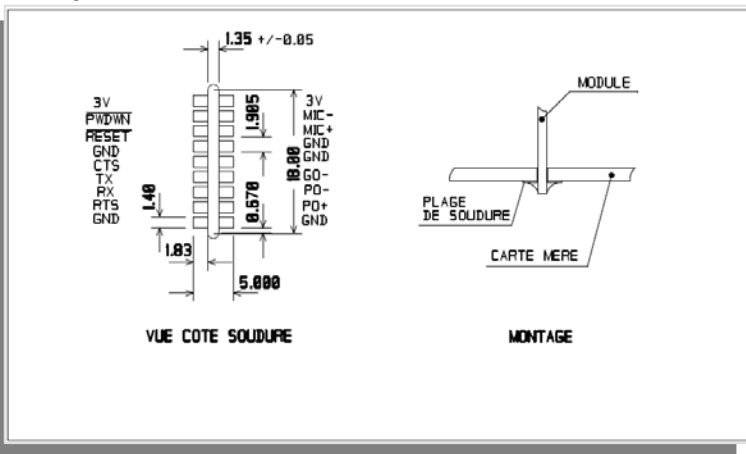

Recommended exclusion zone around antenna

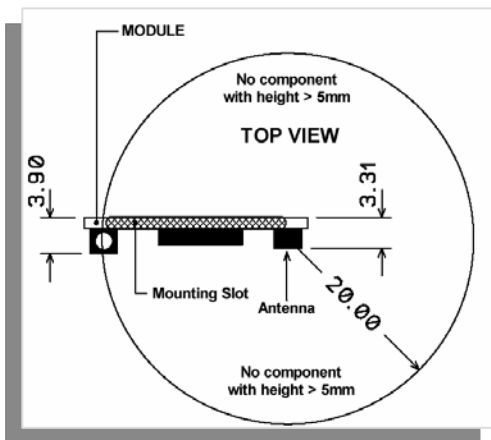

BE CAREFULL

In order to avoid any audio “burst noise” due to Bluetooth[®] RF FHSS bursts, we suggest locating audio paths & components on the opposite side of the mother board. ARF32 module side has to be ground planed to shield audio track side. Try to avoid antenna area. Better to add a serial 100 nH SMD inductor on any active audio signal input, GND included (especially on long wires, like external wired headsets – refer to ARF7213 DemoKit schematics at the end of this User Guide-).

Software management

Non Volatile Default Settings

Parameter	Default Value	Description
BDADDR	HARD CODED	Bluetooth [®] Device Address
Local Name	Serial port device	
PIN Code	0000	Bluetooth [®] PIN Code
Mode	Automatic	Command or Automatic mode
Default connections	0	Up to three default devices to connect on default
SDP database	1 SPP entry : Name : COM1 Authentif. & Encrypt. enabled	Service discovery database, control for supported profiles
UART speed	9600	Speed of the physical UART interface
UART settings	1 Stop bit, parity none	Settings of the physical UART interface
Ports to open	0000 0001	Defines the RF Comm port to open
Link keys	No link keys	Link keys for paired devices
Security mode	2	Security mode
Default audio codec	None	Refer to note below

NOTE

WINBOND W681360 CODEC is set-up during ADEUNIS RF delivery. This setting is lost every “Restore factory settings”. Please use “Set default audio settings” to select WINBOND W681360 Codec.

Operating modes

There are two main operating modes in the module: command mode and transparent mode.

The command mode is used to set up the Bluetooth[®] link between two pieces of Bluetooth[®] equipment.

The transparent mode is used to transfer data between two pieces of Bluetooth[®] equipment.

Command mode

A specific protocol is used to send commands to the Bluetooth[®] module.

The frame format is the following:

All the values are in hexadecimal format.

Start delimiter	Packet type	Operation code	Data length	Checksum	Data	End delimiter
1 byte	1 byte	1 byte	2 bytes	1 byte	<data length> bytes	1 byte

- Start delimiter : 02 (<STX>)
- Packet type: 52 ('R' for request), 69 ('i' for indication), 43 ('C' for confirm)
- Operation code : command dependent
- Data length: size of data. First byte is the Least Significant Byte and second byte is the Most Significant Byte
- Checksum : Sum of all bytes from the packet type field to the data length field
- Data: command data
- End delimiter : 03 (<ETX>)

Example the inquiry command

Start delimiter	Packet type	Operation code	Data length	Check-sum	Data	End delimiter
02	52	00	03 00	55	0A 00 00	03

Frame : 02 52 00 03 00 55 0A 00 00 03

Transparent mode

In this mode all the data received on the UART RX pin are sent by radio to the target Bluetooth[®] module and will be available on the target Bluetooth[®] module UART TX pin.

Mode selection

A specific command (transparent mode) is used in order to switch from command mode to transparent mode.

A specific pattern : "UART break" is used to switch from transparent mode to command mode.

Setting up an direct AUDIO link over SCO/SPP between two ARF32 modules

Quick start using “Simply Blue Commander” SBC software (*) :

Connect one module with the RS232 link to a PC supporting SBC software. Setup “SBC Configuration / Transport layer” at the current baudrate (default 9600), 8 bits, 1 stop, no parity, “Low level driver” & “CTS output flow control” enabled.

Power up the two Bluetooth® modules. SBC must return:

< Rx: Event: SimplyBlue Ready, SW Version: 0212

It means Master Module, serial port setup and connection are OK

Open “SBC ARF32 AUDIO over SCO/SPP quick start” commands sub directory.

- > Click “BT environment inquiry” & “Send”
 - < All BT devices nearby send their own BDADDR & Class of Device (SPP modules class of devices = 000000)
- > Click “SPP link establishment”, replace FFs with slave **BDADDR** & “Send”

In bold : address of the target Bluetooth® module, discovered during previous step.

 - < Target module will confirm the connection (State has to be 00)
- > Click “SCO link establishment”, replace FFs with slave **BDADDR** & “Send”

In bold : address of the target Bluetooth® module, discovered during previous step.

 - < Target module will confirm the connection (State has to be 00)
- > Click “Enter SPP transparent mode” & “Send”
 - < Target module will confirm entering transparent mode (State has to be 00)

Now the full duplex AUDIO link is open between the two ARF32 modules. DATA link over SPP is still usable:

- > “(Enter SPP transparent mode)”

You're still able to exchange data or files between modules (parallel to audio link)
- > “(Set CODEC to WINBOND)”

Set audio settings to WINBOND codec (after restore factory settings, default = OK1)
- > “Release SCO link” & “Release SPP link”

Usable to close AUDIO over SCO and / or DATA&AUDIO over SPP link

(*) : SBC software zip package is downloadable from www.adeunis-rf.com web site.

Final use with a PC terminal or a microcontroller

Power up the two Bluetooth[®] modules. Connect one module with the RS232 link to a PC or Notebook or PDA. Use a terminal software configured at the current baudrate (9600 by default), 8 bits, 1 stop, no parity, flow control material.

Please find below a typical request / respons sequence in order to establish a typical link. All request must be send by the PC / NB / PDA (i.e. the master). All indication and confirm responses are sent by the Bluetooth[®] slave module :

```
> GIAC Inquiry request:          02 52 00 03 00 55 0A 00 00 03
  < Inquiry module indication:    02 69 01 09 00 73 34 BE 1F 17 00 08 00
                                00 00 03
```

In bold: address of the target Bluetooth[®] module. This address will be used within the command

SDAP Connect and the command SPP Connect

```
  < Inquiry module confirm:       02 43 00 01 00 44 00 03

> SDAP connect request:         02 52 32 06 00 8A 34 BE 1F 17 00 08 03
  < SDAP connect module confirm: 02 43 32 01 00 76 00 03

> SDAP service browse SPP request: 02 52 35 02 00 89 01 11 03
  < SDAP service browse SPP module confirm: 02 43 35 0D 00 85 00 01 02 10 01 11 01
                                          05 43 4F 4D 31 00 03

> SDAP disconnect request:      02 52 33 00 00 85 03
  < SDAP disconnect module confirm: 02 43 33 01 00 77 00 03

> SPP connect request:          02 52 0A 08 00 64 01 34 BE 1F 17 00 08
                                1 03
  < SPP connect module confirm:    02 43 0A 02 00 4F 00 01 03
  < SPP connect module indication: 02 69 3E 04 00 AB 01 0C 00 00 03
```

It is recommended to verify that the Audio CODEC configured within the both audio module (Master and Slave) is the MC145483 by using the command

Get Active Audio Settings: 02 52 5A 00 00 AC 03

*< Get active audio settings module confirm: 02 43 5A 03 00 A0 00 **01** 00 03*

If the value in bold within the Get active audio settings confirm is not 01 (MC145483 CODEC) please send the Set Active Audio Settings command below for the both audio module (Master and Slave).

Set Active Audio Settings: 02 52 59 02 00 AD 01 00 03

< Set active audio settings module confirm: 02 43 59 01 00 9D 00 03

*Establish SCO Link, HV3: 02 52 5D 08 00 B7 **34 BE 1F 17 00 08**
80 00 03*

*< Establish SCO link HC3 module confirm: 02 43 5D 07 00 A7 00 **34 BE 1F 17**
00 08 03*

*< Establish SCO link HC3 module indication: 02 69 5D 07 00 CD 00 **34 BE 1F 17**
00 08 03*

Now, you can exchange audio between the two connected Bluetooth® modules.

In order to also exchange data the “Enter transparent mode” command must be sent.

Enter transparent mode : 02 52 11 01 00 64 01 03

< Enter transparent mode module confirm : 02 43 11 02 00 56 00 01 03

To come back to the command mode, send an “UART break”.

Advanced commands

Other commands are available when in command mode. Please refer to the National Semiconductors “Simply Blue Commander Software” and “LMX9830 Software User Guide”, both downloadable from ADEUNIS RF web site.

Setting up “handsfree”, “headset audio gateway” or “headset” using Bluetooth Audio profiles

When connected, ARF32 Audio modules act as a full duplex serial link over SPP (for data) combined with SCO (mainly for PCM audio); the associated host becomes able to use data link to send / receive generic AT commands and SCO link for audio exchange in order to be able to interface standard Bluetooth[®] audio peripherals like Headset (module is the Audio Gateway) or Audio Gateway (module becomes the Headset).

IMPORTANT NOTE: “Embedded profiles” **versus** “Supported profiles”

- Embedded profiles : GAP, SDAP, SPP where module is standalone usable
- Supported profiles: HFP, HSP, AG where module has to be completed with a CPU in charge of AT commands interfacing management.

Acting as HANDSFREE Audio Gateway

Using ARF32 module as a hands free gateway allow user to directly link with any standard Bluetooth[®] Headset without managing “Open/Release” buttons (as a mobile phone headsets does). Only audio mic and earphone are used.

Step 1: Opening SPP and pairing

The module’s fixed PIN has to be modified according to the used audio peripheral PIN (“1234”, for example only). *(For more details, please refer to 6.2.17 / LMX9830 SW user guide)*

Set Fixed PIN “1234”: 02,52,17,05,00,6E,54,**31,32,33,34**,03
< module confirm: 02,43,17,01,00,5B,00,03

Pairing is triggered on audio peripheral and SPP connection is opened on ARF32 Gateway.

Establish SPP connection with BdAddr XX XX XX XX XX XX audio peripheral:
 02,52,0A,08,00,64,01,XX,XX,XX,XX,XX,XX,01,03
 < module confirm: 02,43,0A,02,00,4F,00,01,03...

Step 2: Opening SCO for full duplex audio

SCO link is now open to establish full duplex audio link.

Establish SCO link with BdAddr XX XX XX XX XX XX audio peripheral:
 02,52,5D,08,00,B7,XX,XX,XX,XX,XX,XX,80,00,03
 < module confirm: 02,43,0A,02,00,4F,00,01,03...

Headset is now operating as Hands Free with audio In & Out on the ARF32 gateway.

NOTES

It's possible to also open SPP transparent mode for any data transfer if supported by the peripheral (Keep in mind about 30% "air" bandwidth is used by SCO audio link).

Step 3: Release the link.

Simply release the SPP link (after exiting from transparent mode with an "UART break", if needed).

Release SPP link: 02,52,0D,01,00,60,01,03
 < module confirm: ...

NOTES

Some headsets "beep" when link is released.

Using full HEADSET profile

As previously explained, when ARF32 is connected, both DATA & AUDIO links are available; it means it's possible to use data link to send / receive generic AT Commands used by standard Bluetooth[®] audio peripherals. For example, when interfacing with a Mobile Phone Headset, it becomes possible to use "HEADSET Profile" to manage to headset's buttons. On the other side, if ARF32 is used as a headset, it can be seen from distant gateways as a "real" headset.

NOTES

Because, these explanations are long and redundant with NS user guide, we only mentioned generic commands names :

For complete sequence and opcodes, please refer to 5.4 / LMX9830 SW user guide

Acting as HEADSET Audio Gateway HSAG**Step 1: Modifying Service from "SPP Serial Port" to "HSAG Audio Gateway"**

The module's NVM Service Database has to be modified to be able to "be seen" as a Gateway instead of a Serial Port named "COM1". *(For more details, please refer to 6.2.13 / LMX9830 SW user guide)*

SDP Delete All SDP Records : (6.2.13.3 / LMX9830 SW user guide)

Note : Now NVS Service Database is empty; in this example ARF32 module will only support one profile: headset audio gateway

Store Audio Gateway SDP Record: (5.4.2.2/ LMX9830 SW user guide)

Note : Better to use Simply Blue Commander to get full SDP string which is very long and complicated.

Store Class of Device : (6.2.14.5/ LMX9830 SW user guide)

Note : **52204** is class N° for mobile phone (which is an audio gateway)

Write Local Name "AUDIO GATEWAY" (optional):(6.2.14.2/ LMX9830 SW user guide)

Now, ARF32 module can only "be seen" as a HEADSET Audio Gateway, supporting Audio Gateway Service, having a "Mobile Phone" class of device and named 'AUDIO GATEWAY'.

NOTES

In the previous example, we've deleted all services before recording Audio Gateway one. Keep in mind it's possible to simply add the new service to existing ones and affect it to a new RFCOMM port; ARF32 module supports both SPP and HSAG depending on RFCOMM port used to access it *(5.4.3.2 & 3/ LMX9830 SW user guide)*.

Step 2: Connecting to a standard Bluetooth® Headset using ARF32 as HSAG

First example described sequence for connection coming from ARF32 HSAG to standard BT Headset (For more details, please refer to 5.4.3.5 / LMX9830 SW user guide)

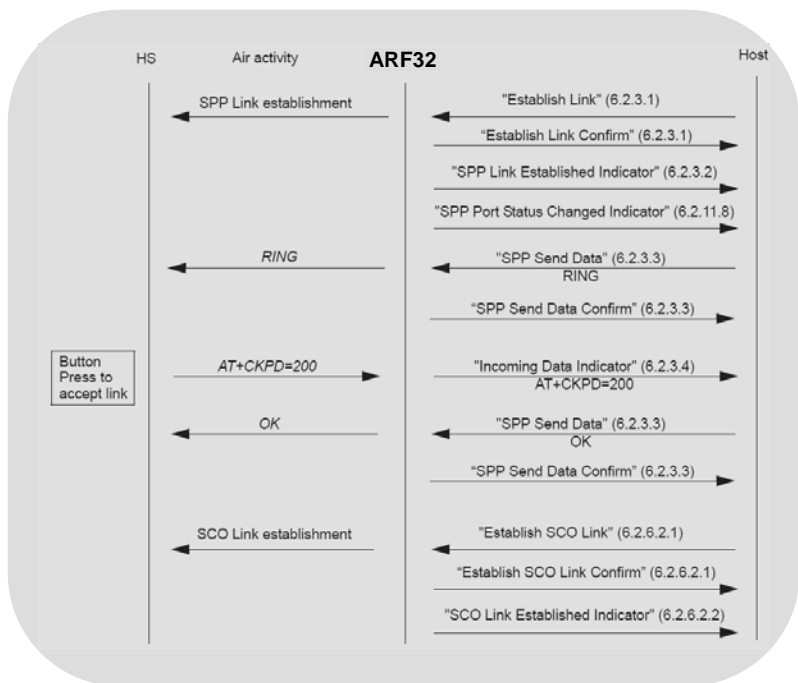

NOTES

Some headsets also support volume control through additional AT commands; SPP link remains available for such control.

Second example described sequence for connection coming from standard BT Headset (using buttons) to ARF32 used as HSAG (For more details, please refer to 5.4.3.5 / LMX9830 SW user guide)

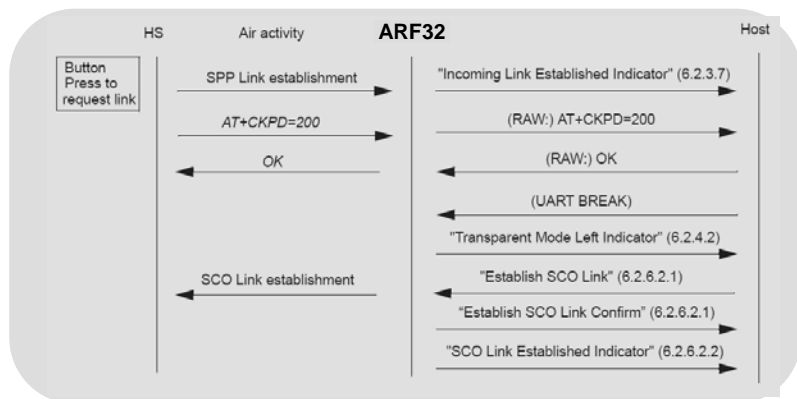

Acting as HEADSET HS

Step 1: Modifying Service from "SPP Serial Port" to "HEADSET"

Exactly the same sequence than HSAG except:

- Service will become "Headset"
- Class of device will become "040422"
- Optionally, it's also possible to change Device name for friendlier one

(For more details, please refer to 5.4.2 / LMX9830 SW user guide)

Specifications

Rough data rate	723 Kbps
UART programmable data rates	Standards from 9.6 to 921.6 kbps
UART ports	TXD - RXD - RTS – CTS NB: About 30% of the rough data rate will be used by the default audio link.
Frequency	FHSS / 2.402 to 2.480 GHz
Radiated RF power	2 mW (3 dBm)
Sensitivity	-85 dBm for BER 10^{-3} / PN9
Operating range	10 m when plugged (with exclusion zone)
Audio bandwidth	3200-3300 Hz
Distortion	< 1,2 % (CCITT filter on)
S/N	> 40 dB (CCITT filter on)
Codec	13 bits PCM codec
Microphone	Analogic input
Speaker	Analogic output (Diff. or single ended)
Operating voltage	3V nominal (2.85 to 3.6 V)
TX / RX consumption	45 mA
PowerDown current	250 μ A (When software powered down)
Power supply rise time	50 ms
Operating temperature	-25°C / +75°C
Dimensions	25 x 18 x 5 mm

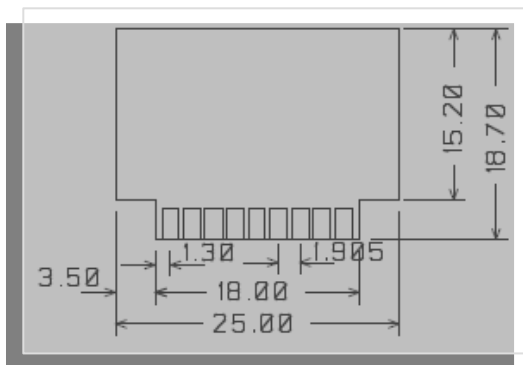

References :

ARF7208A : Plugged Bluetooth® Class 2 Analog Audio/ Data Complete Module.

ARF7208A : Plugged Bluetooth® Class 2 Digital Audio/ Data Complete Module.

ARF7213A : RS232 Audio/ Data Demo Kit.

ARF7213 DemoKit schematic

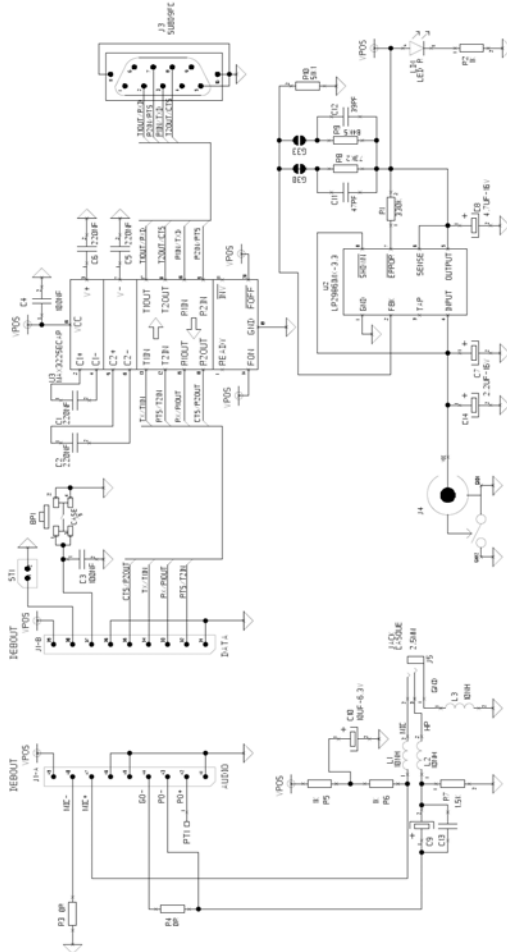

Annex 1 : Firmware and document updates

Firmware	Updates
V1.0	Original version

Document	Updates
V7	More detailed Quick Start Use
V6	Layout
V1.0	Original version