



A^{RF54} UART TTL modules



User Guide

No part of this document may be reproduced or transmitted (in electronic or paper version, photocopy) without Adeunis RF consent.

This document is subject to change without notice.

All trademarks mentioned in this guide are the property of their respective owner.

ADEUNIS RF

283, rue Louis Néel
38920 Crolles
France

Phone +33 (0)4 76 92 07 77

Fax +33 (0)4 76 08 97 46

Ref. 07-12-V5-pcy

Table of Contents

About this Document	2
Overview	3
Interface	3
Mechanical specification	3
Signal description	4
Antenna requirements	6
General purpose I/O extended functionality	6
Radio communication	9
Radio channels & Sub Bands	10
Channel selection	11
Air radio rate selection	11
Channel rejection	11
RSSI reading	12
Transceiver operating mode	13
Command mode	13
Transceiver mode	14
Transceiver state machine	14
Power management : low power mode	15
AT Commands	15
Description	15
Set of commands	16
Register description	17
Specifications	21
Glossary	23
ANNEX 1 : Alternative mounting	23
ANNEX 2 : Firmware updates	24

About this Document

This guide describes the A^{RF54} devices, their options and accessories.

Overview

The A^{RF54} radio transceiver converts data from a serial link into a radio frame to be sent to a similar piece of equipment. The communication is half-duplex. The operating parameters of these radio transceivers (serial link, radio management...) can be fully updated through AT commands via the serial link.

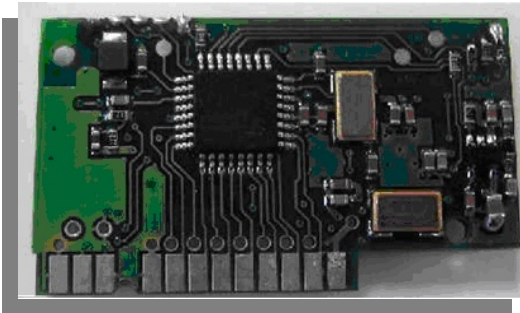

Interface

Mechanical specification

The transceiver is available in only one format: plugged module without antenna.

The PCB width is 12/10 mm

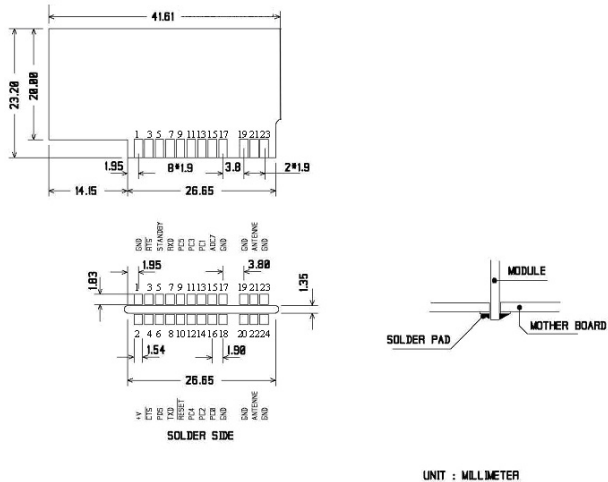

Figure 1: Plugged module mechanical feature

This module has been designed to be plugged (as describe above). If this assembly doesn't suit your requirement, please have a look to Annex 3 (mainly for horizontal mounting).

Signal description

Inter-face Pin	Name	I/O	Description	Alternate function
			<i>Digital interface</i>	
1	GND		Ground	
2	VDD		Operating voltage	
8	TXD	O	Serial data transmission	
7	RXD	I	Serial data reception	

3	/RTS	O	Request To Send RTS = GND, the transceiver is able to receive serial data RTS = VDD, serial data received by the transceiver are lost	
10	/RESET	I	Transceiver Hardware RESET, active LOW.	
5	PWD	I	Power down management	
16	GPI O1 / PC0	I/O	Extended general purpose I/O	
13	GPI O2 / PC1	I/O	Extended general purpose I/O	RS485
14	GPI O3 / PC2	I/O	Extended general purpose I/O	
11	GPI O4 / PC3	I/O	Extended general purpose I/O	RS485
12	GPI O5 / PC4	I/O	Extended general purpose I/O	RS485
9	GPI O6 / PC5	I/O	Extended general purpose I/O or I (input only for the American version)	
6	GPI O7 / PD5	I/O	Extended general purpose I/O	RS485
15	GPI O8 / ADC 7	ADC	Analog to digital conversion	
17, 18	GND		Ground	
			<i>RF interface</i>	
19, 20	GND RF		RF antenna ground	
21, 22	RF in/output		RF antenna IN/OUT.	
23, 24	GND RF		RF antenna ground.	

	Description	Min	Max	Unit
Vil1	Input low voltage except /RESET	-0.5	0.3VDD	V
Vih1	Input High voltage except /RESET	0.6VDD	VDD+0.5	V
Vil2	/RESET Input low voltage	-0.5	0.2VDD	V
Vih2	/RESET Input High voltage	0.9VDD	VDD+0.5	V
	/RESET pulse width	2.5	-	µs

Antenna requirements

External antenna

The antenna has to be added to achieve correct communication between the products. Several possibilities:

General purpose I/O extended functionality

RS485 interface

The S215 register allows enabling the management of the control lines (/RE and DE lines) of most RS485 buffer. The following figures illustrate the RS485 wiring and the configuration required for activating the DE and /RE management. Even one line is sufficient, for more flexibility two different lines could managed the DE and RE RS485 control lines. Hereafter a connection example with both lines or one line only.

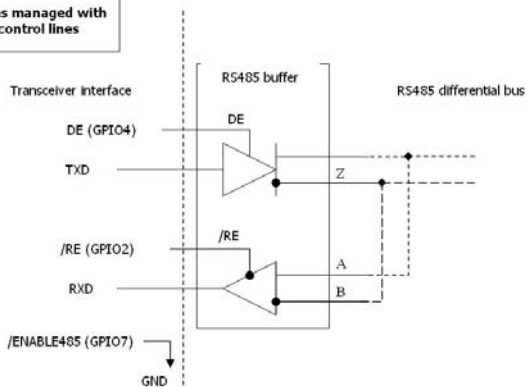
RS485 control lines managed with two different control lines

Configuration required : S215 = 1 and ENABLE485 (GPIO7) tied to GND

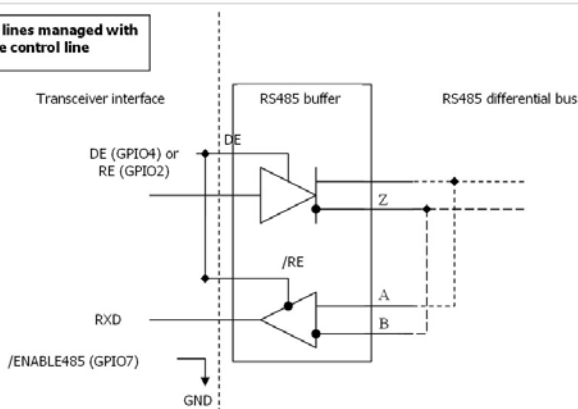
RS485 control lines managed with only one control line

Configuration required : S215 = 1 and ENABLE485 (GPIO7) tied to GND

CAUTION

the /ENABLE485 is read ONLY at power-up. Changing the /ENABLE485 (GPIO7) when the transceiver is already running will not be taken in account. when activating the RS485 interface the GPIO5 will be set as an output.

S215 Value	/ENABLE 485 (GPIO7)	DE/RE state	Note	GPI O2	GPI O4	GPI O5	GPI O7
1	GND	Output	RS485 control lines management	Output	Output	Output	Input
1	VDD	Input	RS232 configuration	Input	Input	Input	Input
0	Input	Input	RS232 configuration	Input	Input	Input	Input

Table 1: R485/232 configuration settings

By default, the DE and RE lines are asserted LOW, allowing the reception of characters from the RS485 differential bus. The DE and RE lines are asserted HIGH only when one or several characters have to be transmitted over the RS485 differential bus: when a radio frame is demodulated, the lines are asserted HIGH and then the data extracted from the radio frame are sent to the module TXD line and therefore to the RS485 differential bus. When the last character has been transmitted over the RS485 differential bus, the lines are asserted LOW.

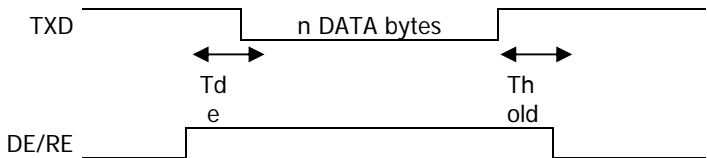

Figure 2: DE/RE timing when data are sent over the serial link

Thold : minimum = 1 μ s

Tde : set according to the S219 register value (see table hereafter)

S219	0	1	2	3	4	5	10	20	40	60	80
Tde min	20 µs	40µs	60 µs	80 µs	100 µs	110 µs	250 µs	480 µs	900 µs	1.3 ms	1.7 ms

Radio communication

This modem has 50 channels over the 902-928 MHz Band used through FHSS transmission. Hopping is possible over the whole range but also selectable over up or down sub-bands. These modes can be selected using AT commands.

Wide Band transmission :

- 3 modes, FHSS over 25 or 50 channels
- 57,6 kbit/s radio rate
- channel spacing: 500 kHz
- Sensitivity : - 106 dBm
- Adjacent channel rejection: see chapter. **Erreur ! Source du renvoi introuvable.**

Narrow Band transmission :

- 3 modes, FHSS over 25 or 50 channels
- 10 kbit/s radio rate
- channel spacing: 500 kHz
- Sensitivity : - 110 dBm
- Adjacent channel rejection: see chapter. **Erreur ! Source du renvoi introuvable.**

This module is designed to operate according to FCC Part 15.247.

NOTE

when delivered this modem is set up in Narrow Band to optimize the range. The RF out power could be adjusted using AT commands (see register S231).

Radio channels & Sub Bands

The 50 channels are available according to the following table :

Channel S200	Frequency (MHz)		Channel S200	Frequency (MHz)
	Low Sub Band			High Sub Band
0	902.75		25	915.25
1	903.25		26	915.75
2	903.75		27	916.25
3	904.25		28	916.75
4	904.75		29	917.25
5	905.25		30	917.75
6	905.75		31	918.25
7	906.25		32	918.75
8	906.75		33	919.25
9	907.25		34	919.75
10	907.75		35	920.25
11	908.25		36	920.75
12	908.75		37	921.25
13	909.25		38	921.75
14	909.75		39	922.25
15	910.25		40	922.75
16	910.75		41	923.25
17	911.25		42	923.75
18	911.75		43	924.25
19	912.25		44	924.75
20	912.75		45	925.25
21	913.25		46	925.75
22	913.75		47	926.25
23	914.25		48	926.75
24	914.75		49	927.25

Figure 3: channels 1 Sub Bands

Channel selection

S220 = 2: Frequency hopping over the whole 50 channels

S220 = 3: Frequency hopping over the lower Sub Band

S220 = 4: Frequency hopping over the higher Sub Band

ATS200? = Viewing the hopping table (Channel numbers)

Entering a new hopping table (50 channels) :

ATS200 = <channel number><cr>

After for each '?' select : <channel number><cr> until the 50th channel.

Air radio rate selection

ATTENTION

Radio rate default setup is 57600 bit/s.

S202 = 0: 10 kbps Narrowband

S202 = 1: 57.6 kbps Wideband

Channel rejection

The graph below shows the typical channels rejection in WideBand (WB) and NarrowBand (NB) modes.

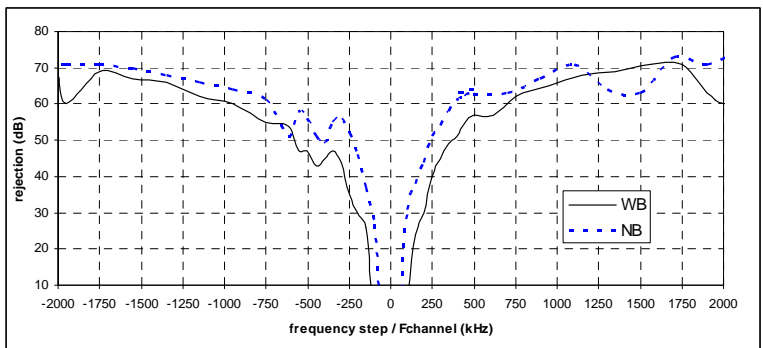

Particular attention is required for product installation. In the case where several links must work in the same area (independently of the channel positions), the minimum distance between 2 products belonging to different radio links is 3 meters. Even with this precaution (depending of the product environment), channel rejection could be reduced.

RSSI reading

The RSSI (Received Strength Signal Indicator) gives an indication for the received power level on the first channel of the hopping table. It could be accessed with `ATS230?<cr>` command.

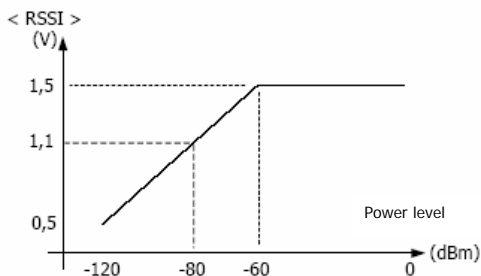

- The RSSI level is only an indication. Use this level with care due to the dispersion between components.
- The schema above could be modified from one to another product. The operating temperature could also have an impact on these dispersions.
- The RSSI level could also indicate the potential presence of any jammer in the used channel.
- The RSSI is a necessary but not sufficient condition to obtain a correct reception.

Transceiver operating mode

Two operating modes are available :

1. Command mode (usage of AT commands)
2. Transceiver or normal mode (serial data are transmitted on radio link)

At power up the transceiver is in transceiver mode: it is able to send / receive data to / from the radio link according to its current parameter configuration.

Command mode

The command mode is used to read and update the modem configuration registers using AT command.

In command mode, the radio is inhibited (reception and transmission), excepted when using test command.

Entering command mode : issues on the serial link a +++ sequence. The sequence of 3 consecutive + characters is accepted only if no character have been seen before and after the +++ sequence. Register (S214) defines the silence duration.

Tips 1 : if you are using a terminal (such as Hyperterm), you have to send the +++ sequence using a text file (first create a text file containing only the +++ characters, and then use in Hyperterm the command "Send text file" in the "Transfer menu")

Tips 2:

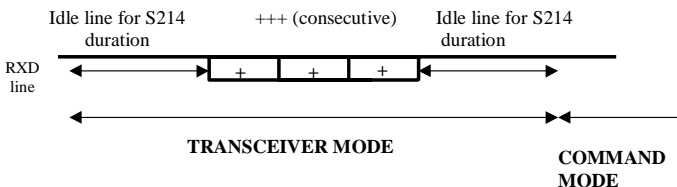

Exiting command mode (return back in transceiver mode): send the serial command

ATO <cr>

Transceiver mode

The transceiver mode used a secured addressed protocol.

The communication is always half-duplex. The radio transmission is processed prior to the radio reception. When the transceiver is sending a radio packet, it is not able to decode any incoming radio packet.

If no data are sent on the serial link, the modem is waiting for radio reception. Each radio packet sent by another modem is received and the validated data extracted from the radio packet are sent on the serial link.

All the data received on the serial link are encapsulated in a radio packet.

In transmission mode, data received on the serial link are sent on the radio link with the following format:

<Preamble><synchro><packet header> DATA <CRC><postamble>. Preamble, synchronisation and postamble are used for the radio reception.

The packet header contains the following fields : packet length, number of retries and packet number, target address.

The CRC follows the data and check the integrity of the radio packet.

The Target Address field is set up with S256 register. The Target Address value 0000 is a broadcast address.

In reception mode: The <Target Address> field of the radio packet is checked (if different of 0000) with the reception address (S252).

If the radio packet address matches the transceiver reception address (S252), DATA (and only DATA) are transmitted on the serial link

Otherwise received data are silently discarded.

Transceiver state machine

When operating in transceiver mode the 'RF transmission' state machine is:

Idle state of the transceiver : by default the transceiver is waiting for incoming data on the RS232 link and for incoming radio packet on the radio link.

Processing incoming RS232 data : the incoming RS232 data are

internally buffered. The buffered data are encapsulated in a radio packet and transmitted. **Processing incoming radio frame** : the valid data are extracted from the incoming radio packet and internally buffered. The buffered data are sent on the fly to the RS232 module output.

Power management : low power mode

The low power mode is managed with the S232 register and the STANDBY pin (5).

Before the activation of the power down mode (ATS232=1<cr>) be sure that the STANDBY pin is pulled to GND in order to keep the module in active mode.

To enable the low power mode S232 register must be set to 1 (ATS232=1<cr>).

To enter in low power mode the STANDBY pin must be pulled to VCC.

To exit the low power mode the STANDBY pin must be pulled to GND.

To disable the low power mode S232 register must be set to 0 (ATS232=0<cr>). The STANDBY pin is not managed.

AT Commands

Description

AT commands are interpreted only when the transceiver is in Command mode.

Command : are used to read and update the modem parameters

- A command starts with the 2 ASCII 'AT' characters. 'AT' means 'Attention' follow with one or several characters or other data.
- Each command is ended with <cr> (carriage return).

Response: is sent back for each command on the serial link. The answer is:

- 'O'<cr> (ASCII character 0x4F) for accepted command (or OK command)
- 'E'<cr> for error
- Specific string when specified

Set of commands

Commands	Description
	Operating mode selection
ATO	Return back to transceiver mode.
<silence>+++<silence>	Command mode activation. The +++ sequence must be preceded and followed by a calibrated silence (no other character)
	Registers management
ATSn?	Displays the Sn register content where n represents the register number. The response has the following format: Sn=y<cr><lf>
ATSn=m	Sets the Sn register value with 'm'. n represents the register number..
AT&W	Saves the new register configuration in EEPROM. Each time you switch on the modem, the EEPROM configuration will be loaded in the modem registers.
AT/S	Displays all register values. The response has the following format: Sxxx=y<cr><lf> for each register.
AT/V	Software version display. The response has the following format: Adeunis RF Versatile Modem II 915 MHz 500mW Vxx.yy<cr><lf>
ATR	Restore the register default values
	Test modes
ATT1	Pure Carrier (data=0) transmission using current channel. The output of this mode is achieved by reception of any character on the serial link.
ATT2	Pure Carrier (data=1) transmission using current channel. The output of this mode is achieved by reception of any character on the serial link.
ATT3-ATT6	Modulation using current channel. The output of this mode is achieved by reception of any character on the serial link. ATT3: 0.9 KHz modulation ATT4: 3.6 KHz modulation ATT5: 14.4 KHz modulation ATT6: 28.8 KHz modulation

Register description

The register value could be updated using the `ATSn=m<cr>` command and displayed using `ATSn?<cr>` command.

At power-up, the previous transceiver configuration is restored from E2PROM (non volatile) to RAM. The registers are located in RAM registers, any modification is performed on RAM registers: To save current register configurations, it is necessary to use the `AT&W<cr>` command (If not, the updated parameters are lost in case of power shortage).

The registers are shared in 2 types : read only (R) or read/write (R/W)

It is mandatory that the Master modem and the Slave modem have exactly the same registers configuration in term of : hopping table (S200), start channel (S201), channel type (S202), serial parameters (S210, S211, S212, S213), handshake (S216), protocol (S220) and packet retries (S221).

It is recommended to have the same RF OUT level (S231).

Type	Register	Function	Description	Default value	Note
<i>Radio management</i>					
R/W	S200	Hopping table	Hopping table	Default table	4
R/W	S201	Start channel	Start channel number for hopping table	0	
R/W	S202	Channel type	Channel type configuration 0 : Narrow band (10 kbps) 1 : Wide band (57.6 kbps)	1	2
When leaving factory, this product is set up in Narrow Band to optimize the range					
R	S230	RSSI level	Displays the reception level of the latest received message. Response: <code>S230=-xxx dBm<cr><lf></code> with xxx decimal value The RSSI values range from -115 up to -60 dBm.	None	

Type	Register	Function	Description	Default value	Note
R/W	S231	RF OUT level	Adjusts the RF out level 0 => 20 dBm (100 mW) 1 => 23 dBm (200 mW) 2 => 24,5 dBm (<450 mA for USB power supply) 3 => 27 dBm (500 mW)	3	
<i>Serial link</i>					
R/W	S210	Baudrate	Serial link rate in bits/s '1': 1 200 '2': 2 400 '3': 4 800 '4': 9 600 '5': 19 200 '6': 38 400 '7': 57 600	4	1,2,3
R/W	S211	Data length	'7': 7 bits '8': 8 bits	8	2,3
R/W	S212	Parity	'1': none '2': even '3': odd	1	2,3
R/W	S213	Stop bits	'1': 1 stop bit '2': 2 stop bits	1	2,3
R/W	S214	Command timeout	Time out duration for detecting the +++ pattern, unit 10ms. From 1(10ms) up to 100 (1s).	8	1
R/W	S215	Interface type	'0': RS232 only '1': RS232 or RS485 (managed DE/RE lines) (RS485 if pin 6 tied to ground)	1	
R/W	S216	Handshake	'0': hardware RTS mandatory if packet retries register S221 = 1 or 2. '2': none	2	2

Type	Register	Function	Description	Default value	Note
R/W	S219	RS485 delay	Delay between DE activation and the first RS485 transmitted byte From 0 up to 160	3	
<i>Protocol</i>					
R/W	S220	Protocol	'2' = hopping all the band '3' = hopping low band '4' = hopping high band	2	
R/W	S221	Packet retries	Number of radio packet retries From 0 up to 2. It is mandatory to set S216 to 0 (hardware RTS) if S221 = 1 or 2.	0	
R/W	S252	Reception address	From 0 up to FFFF Used in addressed protocol only, for filtering incoming frame	0000	
R/W	S256	Transmission address	From 0 up to FFFF Used in addressed protocol only, added to outgoing frame	0000	
<i>Miscellaneous</i>					
R/W	S232	Power management	0 disable power management (STANDBY input) 1 enable power management (STANDBY input)	0	5

NOTE 1

when a serial speed change is requested, the S214 register value can be automatically set to a value greater or equal than the duration of three characters in the requested speed.

NOTE 2

If the radio rate is equal to the serial baudrate, the radio packet is longer than the serial frame, due to radio protocol overhead. If the current radio rate is 10 kbit/s (Narrow band), a serial baudrate of 4800 bauds can be used without flow control, while using a serial baudrate greater or equal to 9600 bauds will produce data overrun.

We recommend to use RTS handshake (S216=0) for serial baudrate greater or equal to the radio rate in order to avoid FIFO buffer overlap.

For example with serial baudrate greater or equal to 9600 bauds for Narrow band (radio rate 10 kbits/s) and serial baudrate equal to 57600 bauds for Wide band (radio rate 57600 kbits/s).

NOTE 3

when changing the serial link configuration (rate, parity, stop bit...), the answer is done using the old serial link format, the next command must be sent using the new serial format.

For avoiding character lost, you should:

- use the flow control (S216=0),
- or use a serial rate lower to the radio rate,
- or limit the size of serial data to one radio packet.

NOTE 4

(S200 register) see chapter channel selection. **Erreur ! Source du renvoi introuvable.** and chapter radio channels & sub bands.

NOTE 5

(S232 register) see chapter power management.

Specifications

915 MHz North American European version

Embedded protocol	ADEUNIS RF enhanced & versatile RF comms manager
Embedded profiles	Full band FHSS modem Sub-Band FHSS modem Improved Full band FHSS modem Improved Sub-Band FHSS modem
Link set-up and status	Through Hayes commands
Radio rough data rate	10 000 & 57 600 bps
UART programmable format	Serial rate from 1 200 bps to 57,6 kbps
UART TTL ports	TXD – RXD – RTS – CTS or RS485 driving capability
Transceiver multi-modes	Secured or Addressed
Programmable Frequency	902 to 928 MHz / North America
Channelization	Adjusted to improve sensitivity (wide and narrow band)
Programmable Radiated RF power	Up to 500 mW (27 dBm)
Sensitivity	Down to –108 dBm BER 10-3
Operating range (open space)	External antenna : up to 3000 m
RSSI level	RF signal qualification
Operating voltage	Regulated 3.3V nominal (2.7 to 3.6 V)

TX / RX consumption (max)	550 mA / 35 mA
Power Down current	< 1 mA
Operating temperature	-30°C / +70°C
Dimensions	42 x 20 x 4 mm
Standards compliance	FCC Part 15.247

References

ARF7429B : Plugged module without antenna

Glossary

TBD	To Be Defined
NC	Not Connected
NU	Not Used
FHSS	Frequency Hopping Spread Spectrum
FIFO	First In First Out
WB	Wide Band
NB	Narrow Band

ANNEX 1 : Alternative mounting

If the module cannot be plugged directly on the motherboard, it is possible to mount a connector. However, we do not recommend this use to keep the radio stability of the module.

Some references of connector

Module header :

- Vertical Male header: Antelec ref. AM2D 200 26 6 G

Motherboard receptacle :

- Vertical Female receptacle (Through Hole) : Antelec ref. AF2D 200 26 G
- Right Angle Female receptacle (Through Hole) : Antelec ref. AF2C 200 26 49 G
- Vertical Female receptacle (Surface Mount) : Antelec ref. AF2D 200 26 G CMS
- Right Angle Female receptacle (Surface Mount) : Antelec ref. F2C 200 026 G CMS

ANNEX 2 : Firmware updates

Firmware	Updates

Document	Updates
V4.0	NB configuration when leaving factory, electrical specification VIx/VOx
V2.0	Commands update
V1.0	Original version