

UHF Narrow band radio data module **CDT-TX-01/RX-01A 434 MHz**



Operation Guide

Version 2.0 (May 2005)

CIRCUIT DESIGN, INC.

7557-1 Hotaka, Hotaka-machi,
Minamiazumi, Nagano 399-8303 JAPAN
Tel: + +81-(0)263-82-1024
Fax: + +81-(0)263-82-1016

e-mail: info@circuitdesign.jp
<http://www.circuitdesign.jp>

Note:

This operation guide is applied to the receiver CDT-RX-01A. If the product label shows CDT-RX-01, the reference operation guide must be version 1.3

CONTENTS

GENERAL DESCRIPTION & FEATURES	3
SPECIFICATIONS	4
BLOCK DIAGRAM	5
DIMENSIONS	6
PIN DESCRIPTION	8
RECEIVER MODULE OPERATION	10
TEST DATA	13
REGULATORY COMPLIANCE INFORMATION	14
Declaration of conformity	15
CAUTIONS and WARNINGS.....	17

GENERAL DESCRIPTION & FEATURES

Features

- 6 switch inputs and outputs
- Stand by mode in TX module
- Long-range communication using a high sensitivity receiver with MSK modulation
- 4 operation modes in RX
- Photo MOS relay in RX
- Low voltage and low current operation
- Compact body

Applications

- Switching signal transmission
- Remote control for motor operated shutter blinds, garage doors gates etc..
- Industrial signal control for construction sites and factories
- Emergency stop equipment, emergency lights, and alarm systems
- Paging systems
- Security systems

General description

The CDT-01 Telecommand module is a fixed channel transmitter/receiver that is specially designed for switching signal transmission. In addition to the RF part, the module includes a MSK modem and photo MOS relay (RX) in its compact metal housing. This new and unique product concept and design allows many wired products to achieve wireless functions very easily. Simply connect the switches to input ports without any additional components.

Narrow band MSK modulation using a high sensitivity receiver achieves 500-1000 m range and achieves reliable communication in the 434 MHz band.

The appropriate RX signal output can be selected from 4 pre-programmed operations (One shot, Toggle, Switching and Continuous modes).

The interference rejection and practical operating range of the CDT-01 is far better than similar RF modules based on wide band SAW-resonator frequency generators, so it is ideal for various signal transmission applications where long range and low power is required.

SPECIFICATIONS

COMMON SPECIFICATIONS:	
<i>COMMUNICATION TYPE</i>	One way
<i>FREQUENCIES</i>	Fixed channel
	434.075 MHz *Others
<i>FREQUENCY STABILITY</i>	+/- 2.5 KHz (-10 to +55 C)
<i>BAUD RATE</i>	MSK 1200 bps
<i>OPERATING TEMP. RANGE</i>	-20 - +60 degree C
TRANSMITTER:	
<i>TRANSMITTER TYPE</i>	PLL Controlled VCO Fixed Channel.
<i>RF OUTPUT POWER</i>	10 mW
<i>SUPPLY VOLTAGE</i>	+2.2 to +12 V
<i>SUPPLY CURRENT</i>	25 mA
<i>STANDBY CURRENT</i>	1 uA
<i>INPUT</i>	6 switch input (Negative logic)
<i>ANTENNA</i>	L/4 whip antenna
<i>DIMENSIONS</i>	36 x 26 x 8 mm Excluding protruding parts
RECEIVER:	
<i>RECEIVER TYPE</i>	Double superhet, Crystal controlled fixed channel
<i>SENSITIVITY (at 25 C)</i>	-120 dBm (BER 10 ⁻²)
<i>SUPPLY VOLTAGE</i>	+3.0 to +12 V
<i>SUPPLY CURRENT</i>	20 mA at 6 outputs OFF 50 mA at ON
<i>OPERATION MODE</i>	One shot, Toggle, Switching, Continuous modes
<i>OUTPUT</i>	6 Photo MOS relay outputs
<i>OUTPUT RELAY</i>	Max 48 V 100 mA DC
<i>ANTENNA</i>	L/4 whip antenna
<i>DIMENSIONS</i>	53 x 35 x 12 mm Excluding protruding parts

Note: The above specifications are subject to change or improvement without prior notice

*Other frequencies: Please contact Circuit Design, Inc.

BLOCK DIAGRAM

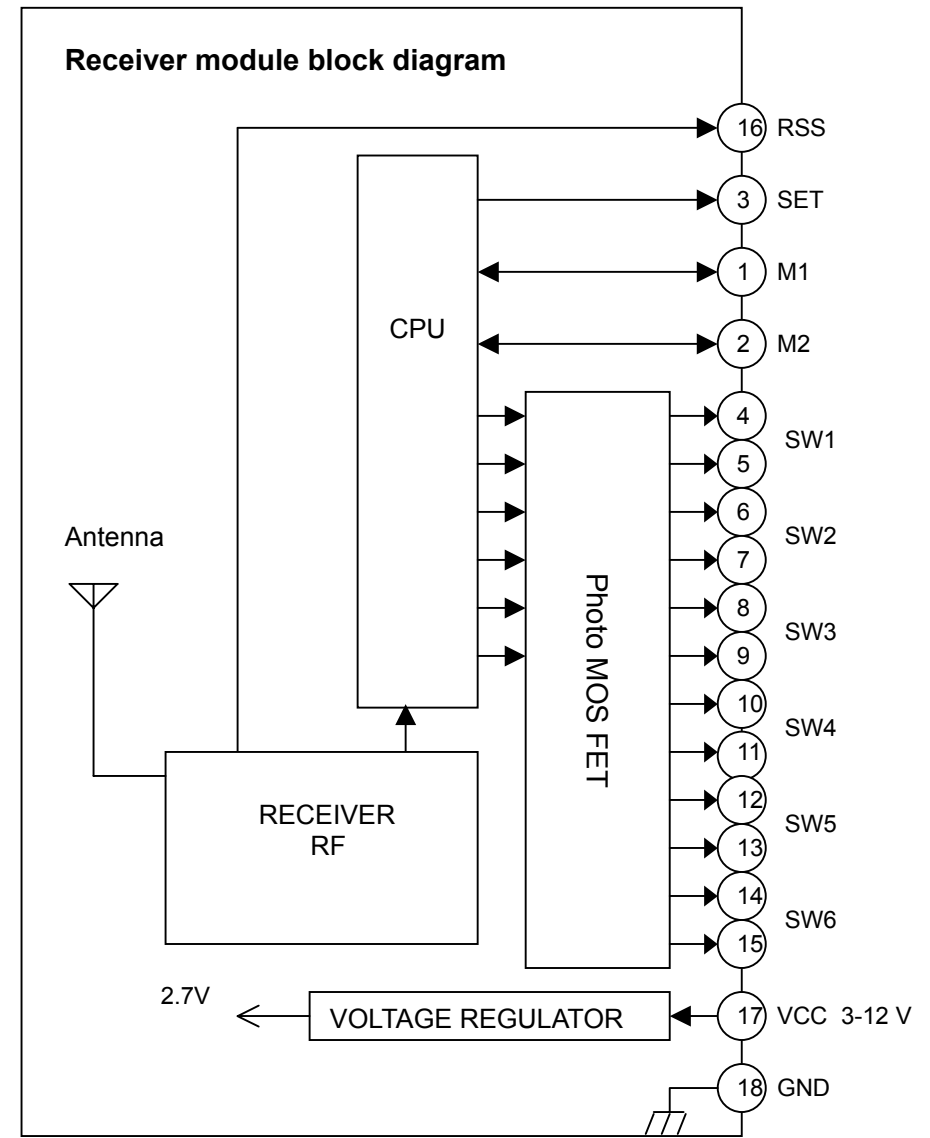
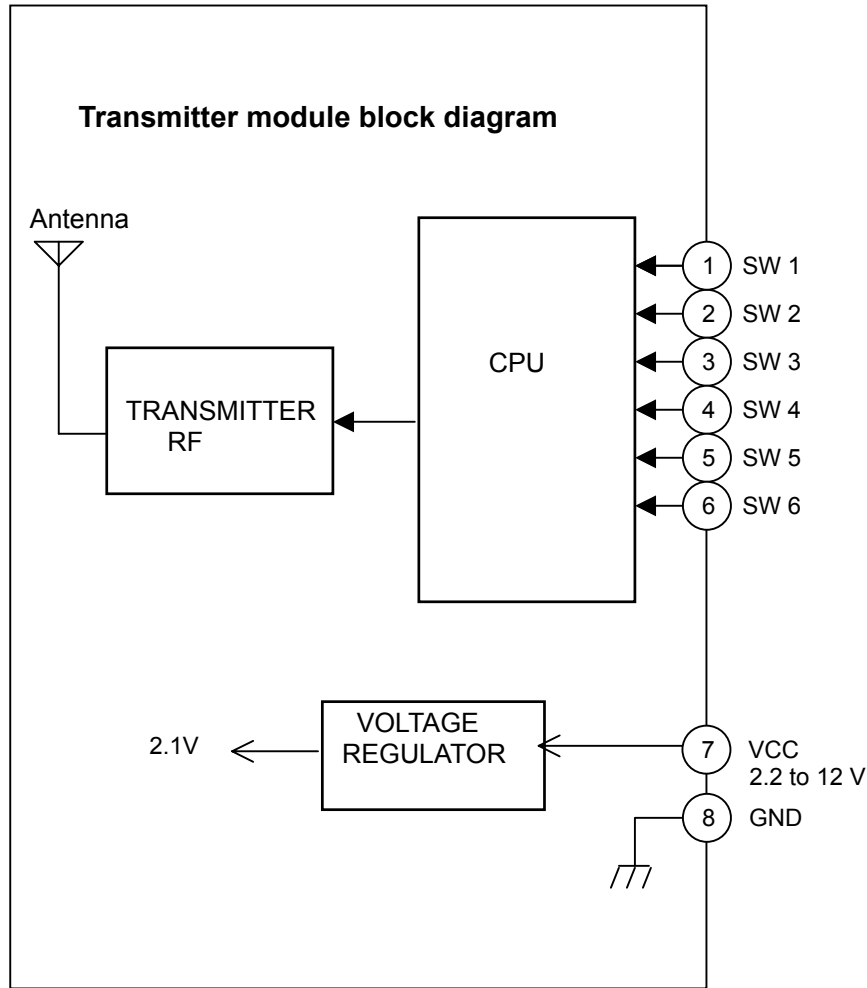

DIMENSIONS (Footprint)

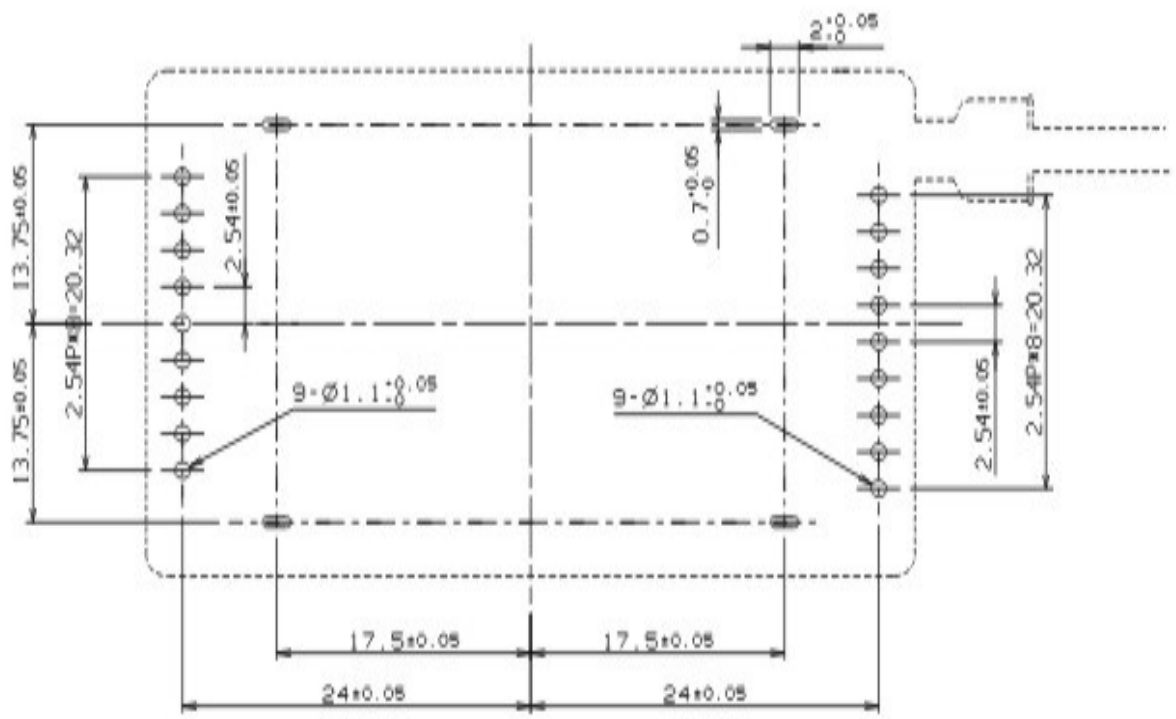
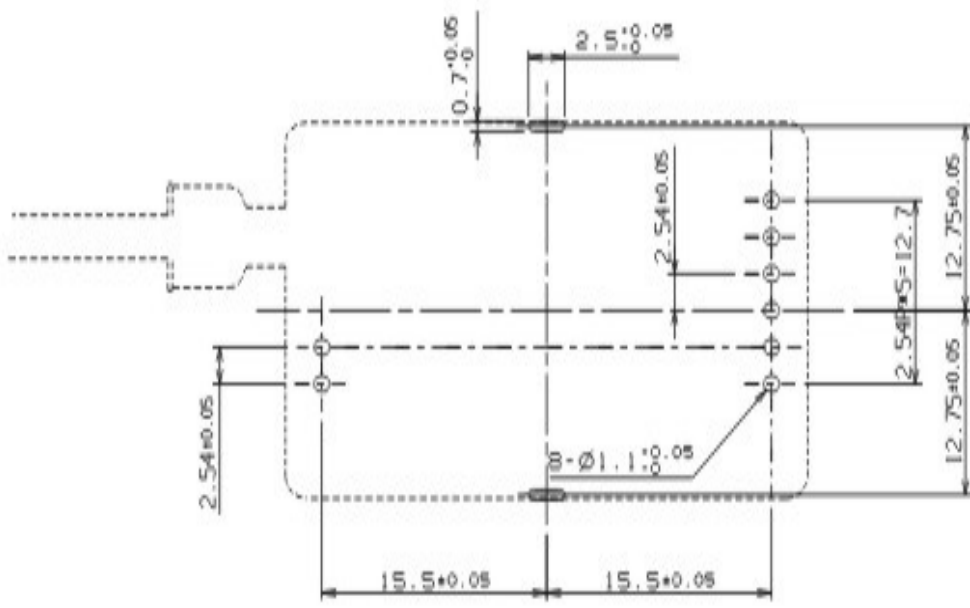

PIN DESCRIPTION

CDT-TX-01 transmitter module

Pin No.	Pin name	I/O	Description
1-6	SW 1 - 6	I	<p>Switch input ports.</p> <p>The switching signal is transmitted when any of the ports become GND level. Normally, switching is momentary and the module goes into stand-by mode (< 1 uA) after transmission.</p> <p>4 operation modes are programmed in the receiver. Different signal outputs are available in each mode. Please refer to the section "Receiver module operation mode"</p>
7	Vcc	I	<p>Power supply plus (+) terminal.</p> <p>Voltage range is 2.2 – 12 V</p> <p>It is recommended to connect an electrolytic capacitor of 10 uF (or greater capacitance) close to the terminal.</p> <p>Please be sure not to connect a power supply with an incorrect polarity.</p>
8	GND	I	<p>Power supply minus (-) terminal.</p> <p>GND also functions as antenna radial. It is recommended to design the GND pattern as wide as possible to stabilize operation and to increase antenna efficiency.</p>

Transmitter antenna

The standard antenna provided at shipment is a flexible $\frac{1}{4}$ lambda antenna that provides maximum radio emissions.

The flexible antenna can be located inside the case of the equipment. The radio module should be built into a plastic case. A metallic case will greatly decrease the radio transmission. Please ensure that the antenna is placed well away from metallic objects.

Note:

Using other antennas may invalidate regulatory compliance of the transmitter module.

CDT-RX-01A receiver module

Pin No.	Pin name	I/O	Description
1	M1	I/O	Mode input port. [Normal operation mode] and [ID registration setting mode] can be set using the M1, M2 and SET ports. M1 and M2 port will be input ports and the internal CPU will read the mode setting when the power is turned on. After setting is completed, these ports will be output ports. This port will be "L" for 2 seconds after "ID registration" is completed. This port will be "L" until power reset after "All ID erase" is completed.
2	M2	I/O	Mode input port. This port will be "L" after "ID erase" is completed.
3	SET	I	Mode input port. Open: Normal operation mode GND: ID registration setting mode
4 – 15	SW 1 - 16	O	Photo-MOS relay output port. The internal circuit is isolated. It is also isolated between each terminal. As it can be connected to a load up to 100 mA DC 48 V, it is good for driving external relays and for signal control.
16	RSS	O	Received signal level output port. Field strength is converted to DC level. It can be used as output signal for S-meter (field strength meter)
17	VCC	I	Power supply plus (+) terminal. Voltage range is 3 – 12 V It is recommended to connect an electrolytic capacitor of 10 uF (or greater capacitance) close to the terminal. Please be sure not to connect a power supply with an incorrect polarity.
18	GND	I	Power supply minus (-) terminal. GND also functions as antenna radial. It is recommended to design the GND pattern as wide as possible to stabilize operation and increase antenna efficiency.

Receiver antenna

The standard antenna is a flexible $\frac{1}{4}$ lambda antenna that provides maximum radio emissions.

The receiver antenna can be removed and can be replaced with a high gain antenna or Yagi antenna that can extend the range of communication. (1 km<)

The flexible antenna can be located inside the case of the equipment. The radio module should be built into a plastic case. A metallic case will greatly decrease the radio transmission. Please ensure that the antenna is placed well away from metallic objects

RECEIVER MODULE OPERATION MODE

The operation mode of the CDT-RX-01A is set by the SET, M2 and M1 ports when the power is turned on. There are two modes “Normal operation mode” and “ID registration setting mode” in RX.

Please refer to “Receiver output sequence” for information about the Normal operation mode.

The ID number of the transmitter must be registered at the receiver in order to prevent any unwanted activation of the receiver module. This operation should be performed before use of the module in the Normal operation mode.

Mode setting port			Receiver module operation		Sign for completion	
SET	M2	M1				
OPEN	OPEN	OPEN	Normal Operation Mode	One shot		
OPEN	OPEN	GND		Toggle		
OPEN	GND	OPEN		Switching		
OPEN	GND	GND		Continuous		
					M1	M2
GND	OPEN	OPEN	ID registration	ID registration	“L” for 2 s	
GND	OPEN	GND	Setting mode	ID erase		“L” for 2 s
GND	GND	OPEN		All ID erase	L	

Fig 1 Receiver module mode settings

ID registration

A 32-bit unique ID number is stored in the EEPROM of transmitter at the factory.

The receiver module has a register for ID registration.

The ID number of the transmitter must be saved in the register of the receiver. The register is a shift register and can store a maximum of 100 ID numbers.

(A) ID registration

1. Set the mode-setting ports of the receiver for ID registration then turn the power on. See fig 1 for mode settings.
2. Send a signal from the transmitter. Once the receiver receives data from the transmitter, the receiver recognizes the ID number and stores the number in the register automatically.
3. The M1 port will be Low for 2 seconds after registration is completed
If ID number registration is conducted when the receiver register is full (100 transmitter ID numbers are stored), oldest registered ID number will be erased as below.

Note: Numbers (1,2, .. 100) in the following figure are transmitter numbers, and the actual ID is 32-bit data.

Receiver register

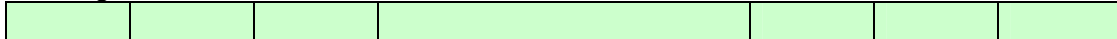

Stored ID number "1"

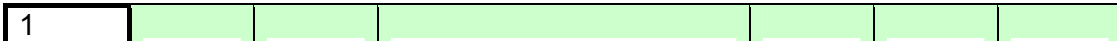

Stored ID number "2"



Total of 100 ID numbers stored in the receiver register

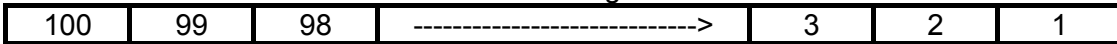

When 101 are stored, the oldest registered number "1" will be erased.

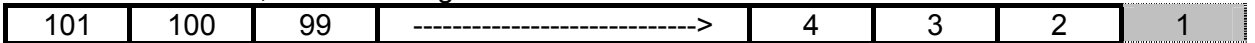

Erase

If the same ID number is stored, registration will be as follows.

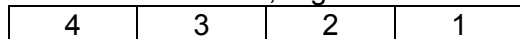

Stored ID number "2"

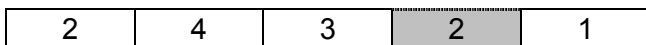

Erase (the identical number "2" will be erased)

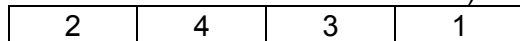

(B) ID erase

1. Set the mode setting ports of the receiver for ID erase. See fig.1 for mode setting.
2. Send any signal from the transmitter. Once the receiver receives data from the transmitter, the receiver recognizes the ID number and erases the number from the register automatically.
3. The M2 port will be Low for 2 seconds after registration is completed.

Example: ID numbers "1", "2", "3", "4" have been registered.

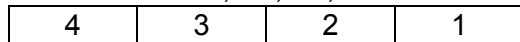

Transmitter ID number "3" transmits a signal.



ID number "3" will be erased

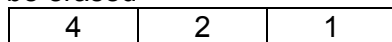

(C) ALL ID erase

1. Set the mode setting ports of the receiver for All ID erase. See fig.1 for mode settings.
2. All ID numbers in the register will be erased if this mode is set for 5 seconds.
3. The M1 port will be Low until power is restarted.

Receiver output sequence

One shot mode

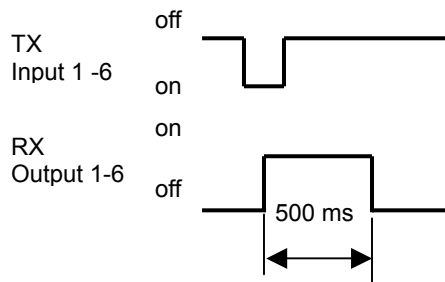

TX input turned ON -> Receiver output turned ON for 500 ms.

TX input	RX output
Input 1	Output 1
Input 2	Output 2
Input 3	Output 3
Input 4	Output 4
Input 5	Output 5
Input 6	Output 6

Toggle mode

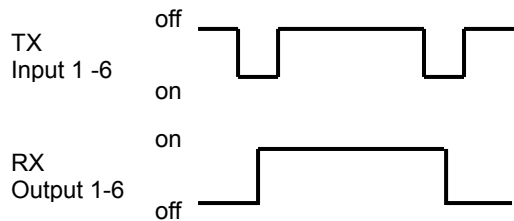

TX input turned ON -> Receiver output turned ON until same TX input is turned ON again.

TX input	RX output
Input 1	Output 1
Input 2	Output 2
Input 3	Output 3
Input 4	Output 4
Input 5	Output 5
Input 6	Output 6

Switching mode

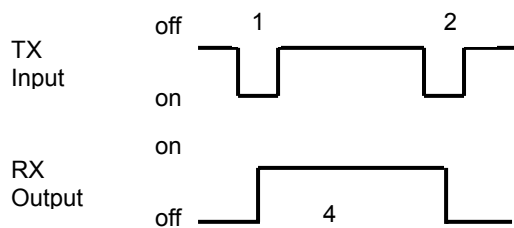

TX input 1 turned ON -> RX output 4 turned ON until TX input 2 is turned ON

Please refer to the chart at right for the relation between TX input and RX output.

TX input	RX output
Input 1	Output 4 ON
Input 2	Output 4 OFF
Input 3	Output 5 ON
Input 4	Output 5 OFF
Input 5	Output 6 ON
Input 6	Output 6 OFF

Continuous mode

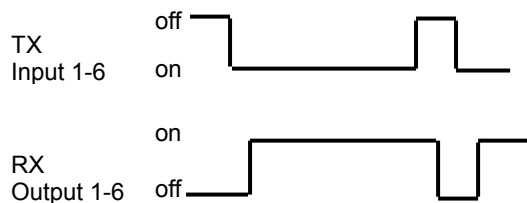

TX input turned ON -> RX output turned ON continuously until the input is turned OFF

TX input	RX output
Input 1	Output 1
Input 2	Output 2
Input 3	Output 3
Input 4	Output 4
Input 5	Output 5
Input 6	Output 6

TEST DATA

RF VS RSSI

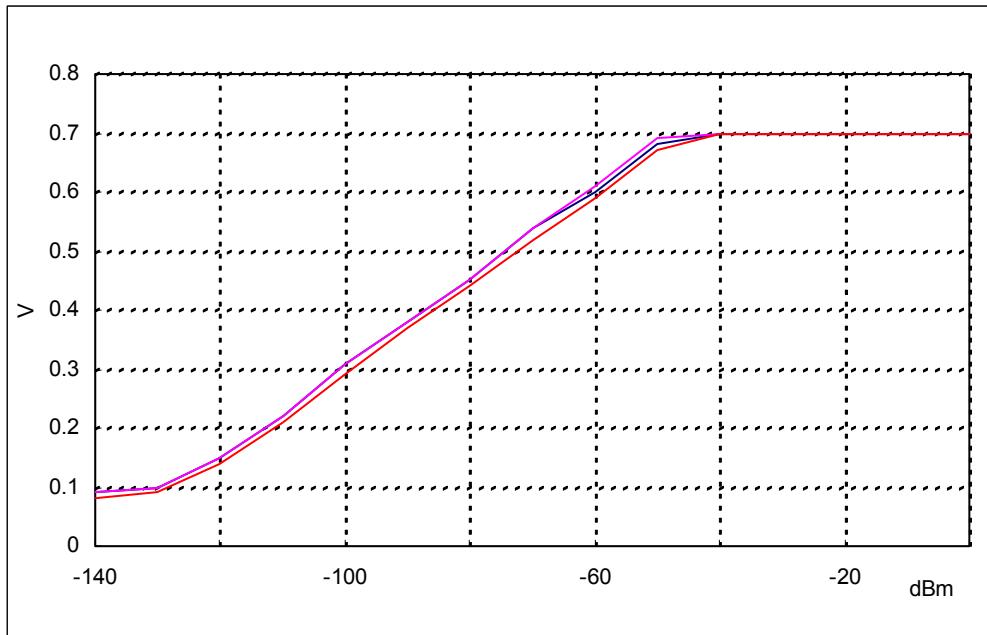

Regulatory compliance information

- The CDT-TX/RX-01A modules are intended to be integrated into the host equipment. The CDT-TX-01 emits carrier signals continuously when any switch is turned on. The user must design the host equipment of the CDT-TX-01 to ensure that the duty cycle of the host equipment is within the requirements of the radio regulations in the country where the equipment is to be used.
- Make sure that the CDT-01 is used within the specified supply voltage range. Applying voltage over/under the rated range may cause malfunction.
- To fulfill the EMC requirements, make sure that the CDT-01 is mounted on your PCB and enclosed in the case of the host equipment. No surface of the module should be exposed.
- For CDT-TX-01, be sure to use the dedicated antenna for the module. A dedicated antenna is provided at shipment. Using other antennas with the CDT-TX-01 may invalidate regulatory compliance.
- CDT-TX-01 has been assessed for conformity with the following standards;
 - EN 300 220-3 V1.1.1
 - EN 301 489-3 V1.2.1
 - IEC60950:2000 (3rd Edition)
- CDT-RX-01 has been assessed for conformity with the following standards;
 - EN 300 220-3 V1.1.1
 - EN 301 489-3 V1.4.1
 - EN 50371 :2002
 - EN 60950 : 2000

Note: Notification requested under 6.4 of R&TTE Directive

Based on Article 6.4 of the R&TTE Directive, radio equipment using frequency bands whose use is not harmonised throughout the Community, the manufacturer or his authorised representative or the person responsible for placing the equipment on the market shall notify the national authority responsible in the relevant Member State for spectrum management of the intention to place such equipment on its national market. Circuit Design's RF modules are designed for embedding in other equipment and radio characteristics are controlled by the final products where our RF modules are embedded. It is the responsibility of the final equipment's manufacturer, his authorised representative or person first placing the product on the community market to declare that the final product meets with the essential requirements of the R&TTE Directive.

If you have any inquiries about regulatory compliance of this product, please contact Circuit Design, Inc. We also recommend you to consult the authorities in the relevant country for detailed regulatory information.

DECLARATION OF CONFORMITY

Directive 99/5/EC

Supplier Name: Circuit Design, Inc.

Supplier Address: 7557-1, Hotaka, Hotaka-machi, Minamiazumi, Nagano

declares on our sole responsibility, that the following product:

Kind of equipment: Transmitter module (CDT-TX-01)

Type-designation: CDT-TX-01 (433.050-434.790MHz)

is/are in compliance with the following norm(s) or document(s):

EN300 220-3 V1.1.1

EN 301 489-3 V1.2.1

IEC60950:2000 (3rd Edition)

Hotaka, Japan Oct.22 2002

Place and date of issue



Manufacturer/Authorized representative
Name and signature

Accredited test laboratory : MIKES BABT SERVICE GmbH,

Ohmstrasse 2-4 94342 Strasskirchen, Germany

DECLARATION OF CONFORMITY

Directive 99/5/EC

Supplier Name: Circuit Design, Inc.

Supplier Address: 7557-1, Hotaka, Hotaka-machi, Minamiazumi, Nagano

declares on our sole responsibility, that the following product:

Kind of equipment: Receiver module (CDT-RX-01A)

Type-designation: CDT-RX-01A (433.050-434.790MHz)

is in compliance with the essential requirements of §3 of the R&TTED.

-Health and safety requirements pursuant to §3 (1)a:

Applied standard(s) or other means of providing conformity:

EN 50371 :2002

EN 60950 :2000

-Protection requirements concerning TMC §3 (1)b:

Applied standard(s) or other means of providing conformity:

EN 301-489-3 V1.4.1 (08.2002)

-Measures for the efficient use of the radio frequency spectrum §3 (2):

Applied standard(s) or other means of providing conformity:

EN 300 220-3 V1.1.1 (09.2000)

Hotaka, Japan June 27, 2005

Place and date of issue



Manufacturer/Authorized representative
Name and signature

Accredited test laboratory : mikes-testingpartners gmbh

Ohmstrasse 2-4 94342 Strasskirchen, Germany

Cautions

- As the radio module communicates using electronic radio waves, there are cases where transmission may be temporarily cut off due to factors in the environment of use or the method of usage. The manufacturer is exempt from all responsibility relating to harm to personnel or other equipment and other secondary damage.
- Do not use the equipment within the vicinity of devices that may malfunction as a result of electronic radio waves from the radio module.
- The manufacturer is exempt from all responsibility relating to secondary damage resulting from the operation, performance and reliability of equipment connected to the radio module.
- Communication performance will be affected by the environment of use, so communication tests should be carried out before actual use.
- Ensure that the power supply for the radio module is within the specified rating. Short circuits and reverse connections may result in overheating, and damage and must be avoided at all costs.
- Ensure that the power supply has been switched off before attempting any wiring work.
- The case is connected to the GND terminal of the internal circuit, so do not allow the '+' side of the power supply terminal to make contact with the case.
- When batteries are used as the power source, avoid short circuits, recharging, dismantling, and compression. Failure to observe this may result in the outbreak of fire, overheating and damage to the equipment. Remove the batteries when the equipment is not to be used for a long period of time. Failure to observe this may result in battery leaks and damage to the equipment.
- Do not use this equipment in vehicles with the windows closed, in locations where it is subject to direct sunlight, or in locations with extremely high humidity.
- The radio module is neither waterproof nor splash proof. Ensure that it is not splashed with dirt or water. Do not use the modules in equipment in which water or other foreign objects may enter the case.
- Do not drop the radio module or otherwise subject it to strong shocks.
- Do not subject the equipment to condensation (including moving it from cold locations to locations with a significant increase in temperature.)
- Do not use the equipment in locations where it is likely to be affected by acid, alkalis, organic agents or corrosive gas.
- Do not bend or break the antenna. Metallic objects placed in the vicinity of the antenna will have a significant effect on communication performance. As far as possible, ensure that the equipment is placed well away from metallic objects.
- The GND for the radio module will also affect communication performance. If possible, ensure that the case GND and the circuit GND are connected to a large GND pattern.

Warnings

- Do not take apart or modify the equipment.
- Do not remove the product label (the label attached to the upper surface of the module.) The use of modules from which the label has been removed is prohibited.

Circuit Design, Inc. All rights reserved

No part of this document may be copied or distributed in part or in whole without the prior written consent of Circuit Design, Inc.

Customers are advised to consult with Circuit Design sales representatives before ordering.

Circuit Design, Inc. believes the furnished information is accurate and reliable. However, Circuit Design, Inc. reserves the right to make changes to this product without notice.